

Advanced[®]
CONTROL



M430 Series

User manual

1. PREFACE

Thanks for choosing M430 series frequency inverter!

This manual introduces how to use the M430 frequency inverter correct. Before you use the frequency inverter, please read this manual carefully and know the safety precautions clearly

NOTICE

- In order to explain the detailed things, some of the pictures are the frequency inverter remove the shape. when you use the frequency inverter, please close and install the coverings, follow the manual to operate.
- Some of the pictures in this manual just for explain, maybe different from your order sample.
- If you have any other questions you can contact with our company

CONTENTS

1. PREFACE	1
CONTENTS	2
2. PRODUCT INFORMATION	11
2.1 NAMING RULE	11
2.2 NAMEPLATE	12
2.3 FREQUENCY INVERTER SERIES TYPE	12
2.4 TECHNICAL SPECIFICATION	13
2.5 PARTS DESCRIPTION	15
3. INSTALLATION	17
3.1 INSTALL ENVIRONMENT	17
3.2 HOW TO INSTALL	17
3.3 MORE THAN TWO INVERTERS INSTALL	17
3.4 EXTERNAL DIMENSION OF FREQUENCY INVERTER	18
3.5 KEYBOARD DIMENSION OF INVERTER	19
4. WIRING	20
4.1 CONNECTION OF PERIPHERAL DEVICES	21
4.2 TERMINAL CONFIGURATION	22
4.3 WIRING CONTROL CIRCUIT TERMINAL CONNECT	28
4.4 INSTALLATION GUIDELINE TO EMC COMPLIANCE	35
5. OPERATION KEYBOARD AND OPERATION	40

5.1 KEYPAD DESCRIPTION	40
5.2 OPERATION PROCESS	44
5.3 RUNNING STATE	46
5.4 SHORTCUT MENU	47
6. DETAILED FUNCTION DESCRIPTION.....	48
F0 GROUP BASIC FUNCTION	48
F1 GROUP START AND STOP CONTROL	56
F2 GROUP MOTOR PARAMETERS.....	61
F3 GROUP VECTOR CONTROL.....	62
F4 GROUP V/F CONTROL	65
F5 GROUP INPUT TERMINALS	68
F6 GROUP OUTPUT TERMINALS.....	74
F7 GROUP DISPLAY INTERFACE	77
F8GROUP ENHANCED FUNCTION.....	82
F9 GROUP PID CONTROL	88
FA GROUP SIMPLE PLC AND MULTI-STEP SPEED CONTROL	92
Fb GROUP PROTECTION FUNCTION	97
FCGROUPSERIALCOMMUNICATION.....	103
Fd GROUP SUPPLEMENTARY FUNCTION	105
FE GROUP FACTORY SETTING.....	105
7. COMMUNICATION PROTOCOL.....	106
7.1 INTERFACES.....	106

7.2 COMMUNICATION MODES	106
7.3 PROTOCOL FORMAT.....	106
7.4 PROTOCOL FUNCTION	107
7.5 NOTE:.....	114
7.6 CRC CHECK.....	115
7.7 EXAMPLE.....	115
8. TROUBLE SHOOTING	119
8.1 FAULT AND TROUBLE SHOOTING	119
8.2 COMMON FAULTS AND SOLUTIONS.....	125
9. MAINTENANCE.....	126
9.1 DAILY MAINTENANCE	126
9.2 PERIODIC MAINTENANCE	127
9.3 REPLACEMENT OF WEARING PARTS.....	128
9.4 GUARANTEE	128
10. SPECIFICATIONS OF BREAKER, CABLE, CONTACTOR AND REACTOR	128
10.1 BRAKE RESISTOR	128
10.2 SPECIFICATIONS OF BREAKER, CABLE, CONTACTOR AND REACTOR.....	129
10.3 SPECIFICATIONS OF INPUT/OUTPUT AC REACTOR AND DC REACTOR.....	129
11. LIST OF FUNCTION PARAMETERS	131

1. SAFETY PRECAUTIONS



WARNING: Points out potential danger which, if not avoided, may cause physical injury or death.



CAUTION: Points out potential danger which, if not avoided, may result in mild or moderate physical injury and damage to the equipment. It's also available to warns about unsafe operations.

In some cases, even the content described in "Note" may also cause serious accidents. So please follow these important precautions in any situations.

1.1.1 Safety attentions

1.1.2 Before install:



Danger

- Open the shape find the control system in water、 parts lost or parts damage, don't install !
- if the product different from the packing list! don't install !
- Carefully handled when loading, otherwise it may damage the inverter !
- Do not use the damaged inverter or inverter with missing parts. Otherwise, there may be risk of injury.
- Do not touch the control system, otherwise it will cause static electricity !

1.1.3 When install:



Danger

- install the inverter on incombustible surface like metal, and keep away from flammable substances. Otherwise it may cause fire.

- Do not lost the set screw of the equipment, especially the screws marked in RED.



Caution

- Do not drop the lead wire stub or screw in the inverter. Otherwise it may damage the inverter !
- Please install the driver in the place where there is no direct sunlight and no shock !
- When more than two inverters are to be installed in one cabinet, due attention shall be paid to the installation locations (refer to Chapter 3 Mechanical and Electrical Installation) to ensure the heat sinking effect !

1.1.4 Wiring:



Danger

- Operation shall be performed by the professional engineering technician. Otherwise there will be danger of electric shock !
- There shall be circuit breaker between the inverter and power supply. Otherwise, there may be fire !
- Make sure the power is disconnected prior to the connection. Otherwise there will be danger of electric shock !
- The earth terminal shall be earthed reliably. Otherwise there may be danger of electric shock !



Danger

- Prohibit the input power connect with the output terminals U、V、W. Don't connect the wrong way about the wiring,pls check the terminals carefully !
- Make sure all the wiring according with the EMC and the stay area's safe standard All the cables must use as manual's reference !
- Don't connect the brake resistor between DC bus (+)、(-), other wire it may cause fire !

1.1.5 Upon Power-on:



Caution

- At power-on, the inverter will perform the security check of the external heavy-current circuit automatically. Thus, at this time please do not touch the terminals U, V and W, or the terminals of motor, otherwise there will be danger of electric shock!
- The inverter is free from dielectric test because this test is performed prior to the delivery. Otherwise accident may occur!



Danger

- must close the frequency inverter shape then power on, otherwise electric shock occur!
- All the cables must use as manual's reference, according with the manual's connect diagram, otherwise accident occur!

1.1.6 After Power-on:



Danger

- Do not open the cover of the inverter upon power-on. Otherwise there will be danger of electric shock!
- Do not touch the inverter and its surrounding circuit with wet hand. Otherwise there will be danger of electric shock!
- Do not touch the inverter terminals (including control terminal). Otherwise there will be danger of electric shock!
- At power-on, the inverter will perform the security check of the external heavy-current circuit automatically. Thus, at this time please do not touch the terminals U, V and W, or the terminals of motor, otherwise there will be danger of electric shock!



Danger

- If parameter identification is required, due attention shall be paid to the danger of injury arising from the rotating motor. Otherwise accident may occur !
- Do not change the factory settings at will. Otherwise it may damage the equipment !

1.1.7 In Service:



Danger

- Do not touch the fan or discharge resistor to sense the temperature. Otherwise, you may get burnt !
- Detection of signals during the operation shall only be conducted by qualified technician. Otherwise, personal injury or equipment damage may be caused !



Caution □

- During the operation of the inverter, keep items from falling into the equipment. Otherwise, it may damage the equipment !
- During the operation of the inverter, keep items from falling into the equipment. Otherwise, it may damage the equipment !

1.1.8 Maintenance:



Danger

- Do not repair and maintain the equipment with power connection. Otherwise there will be danger of electric shock !
- be sure to conduct repair and maintenance after the charge LED indicator of the inverter is OFF.

Otherwise, the residual charge on the capacitor may cause personal injury!

- **The inverter shall be repaired and maintained only by the qualified person who has received professional training. Otherwise, it may cause personal injury or equipment damage!**
- **Carry out parameter setting after replacing the inverter, all the plug-ins must be plug and play when power outage!**

1.2 Precautions

1.2.1 Motor Insulation Inspection

When the motor is used for the first time, or when the motor is reused after being kept, or when periodical inspection is performed, it shall conduct motor insulation inspection so as to avoid damaging the inverter because of the insulation failure of the motor windings. The motor wires must be disconnected from the inverter during the insulation inspection. It is recommended to use the 500V megameter, and the insulating resistance measured shall be at least 5MΩ.

1.2.2 Thermal Protection of the Motor

If the ratings of the motor does not match those of the inverter, especially when the rated, please adjust some parameters let the KW suitable for the motor.

1.2.3 Running with Frequency higher than Standard Frequency

This inverter can provide output frequency of 0Hz to 400Hz. If the user needs to run the inverter with frequency of more than 50Hz, please take the resistant pressure of the mechanical devices.

1.2.4 Vibration of Mechanical Device

The inverter may encounter the mechanical resonance point at certain output frequencies, which can be avoided by setting the skip frequency parameters in the inverter.

1.2.5 Motor Heat and Noise

Since the output voltage of inverter is PWM wave and contains certain harmonics, the temperature rise, noise and vibration of the motor will be higher than those when it runs at standard frequency.

1.2.6 Voltage-sensitive Device or Capacitor Improving Power Factor at the Output Side

Since the inverter output is PWM wave, if the capacitor for improving the power factor or voltage-sensitive resistor for lightning protection is mounted at the output side, it is easy to cause instantaneous over current in the inverter, which may damage the inverter. It is recommended that such devices not be used.

1.2.7 Switching Devices like Contactors Used at the Input and Output terminal

If a contactor is installed between the power supply and the input terminal of the inverter, it is not allowed to use the contactor to control the startup/stop of the inverter. If use of such contactor is unavoidable, it shall be used with interval of at least one hour. Frequent charge and discharge will reduce the service life of the capacitor inside the inverter. If switching devices like contactor are installed between the output end of the inverter and the motor, it shall ensure that the on/off operation is conducted when the inverter has no output. Otherwise the modules in the inverter may be damaged.

1.2.8 Use under voltage rather than rated voltage

If the series inverter is used outside the allowable working voltage range as specified in this manual, it is easy to damage the devices in the inverter. When necessary, use the corresponding step-up or step-down instruments to change the voltage.

1.2.9 Change Three-phase Input to Two-phase Input

It is not allowed to change the M430 series three-phase inverter into two-phase one. Otherwise, it may cause fault or damage to the inverter.

1.2.10 Lightning shock protection

The series inverter has lightning over current protection device, and has certain self-protection capacity against the lightning. In applications where lightning occurs frequently, the user shall install additional protection devices at the front-end of the inverter.

1.2.11 Altitude and Derating

In areas with altitude of more than 1,000 meters, the heat sinking effect of the inverter may turn poorer due to rare air. Therefore, it needs to derate the inverter for use. Please contact our company for technical consulting in case of such condition.

1.2.12 Special Use

If the user needs to use the inverter with the methods other than the recommended wiring diagram in this manual, such as shared DC bus, please consult our company.

1.2.13 Note of Inverter Disposal

The electrolytic capacitors on the main circuit and the PCB may explode when they are burnt. Emission of toxic gas may be generated when the plastic parts are burnt. Please dispose the inverter as industrial wastes.

1.2.14 Adaptable Motor

- 1) The standard adaptable motor is four-pole squirrel-cage asynchronous induction motor. If such motor is not available, be sure to select adaptable motors in according to the rated current of the motor. In applications where drive permanent magnetic synchronous motor is required, please consult our company;
- 2) The cooling fan and the rotor shaft of the non-variable-frequency motor adopt coaxial connection. When the rotating speed is reduced, the cooling effect will be poorer. Therefore, a powerful exhaust fan shall be installed, or the motor shall be replaced with variable-frequency motor to avoid the over heat of the motor.
- 3) Since the inverter has built-in standard parameters of the adaptable motors, it is necessary to perform motor parameter identification or modify the default values so as to comply with the actual values as much as possible, or it may affect the running effect and protection performance;
- 4) The short circuit of the cable or motor may cause alarm or explosion of the inverter. Therefore, please conduct insulation and short circuit test on the newly installed motor and cable. Such test shall also be conducted during routine maintenance. Please note that the inverter and the test part shall be completely disconnected during the test.

2. PRODUCT INFORMATION

2.1 Naming rule

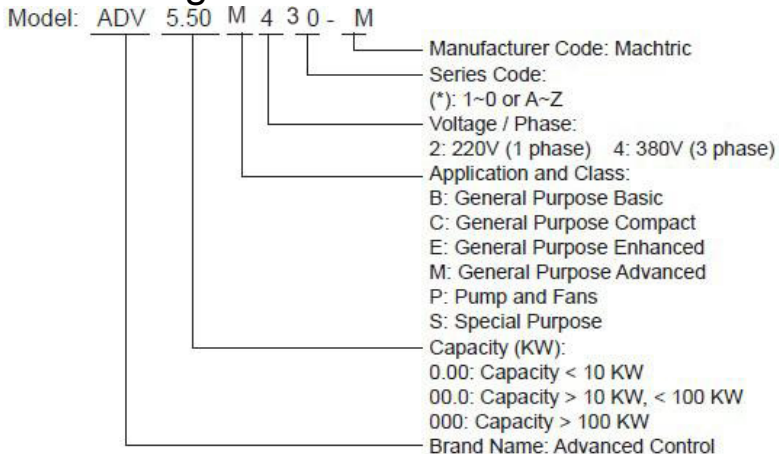

2.2 Nameplate

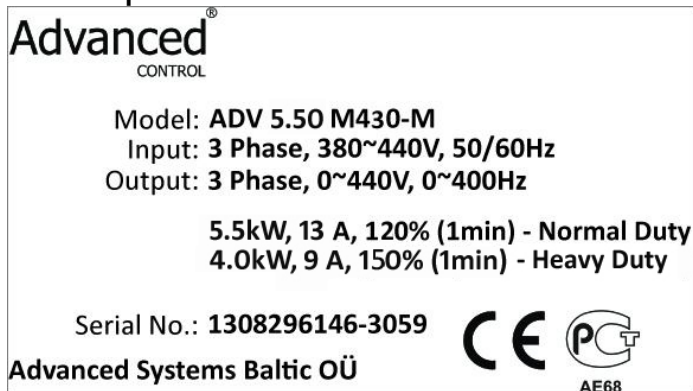

2.3 Frequency inverter series type

Type	Input V	Rated output (KW)	Rated input current (A)	Rated output current (A)	Motor (KW)
ADV 0.75 M430-M	3 Phase 380V	0.75	3.4	2.5	0.75
ADV 1.50 M430-M		1.5	5.0	3.7	1.5
ADV 2.20 M430-M		2.2	5.8	5	2.2

Advanced Control Assumes the promotion of energy-saving technology as its own task!

ADV 5.50 M430-M	3 Phase 380V Range: -15% ~+15%	5.5/4.0	15/10	13/9	5.5/4.0
ADV 7.50 M430-M		7.5/5.5	20/15	17/13	7.5/5.5
ADV 11.0 M430-M		11.0/7.50	26/20	25/17	11.0/7.5
ADV 15.0 M430-M		15.0/11.0	35/26	32/25	15.0/11.0
ADV 18.5 M430-M		18.5/15.0	38/35	37/32	18.5/15.0
ADV 22.0 M430-M		22.0/18.5	46/38	45/37	22.0/18.5
ADV 30.0 M430-M		30.0/22.0	62/46	60/45	30.0/22.0
ADV 37.0 M430-M		37.0/30.0	76/62	75/60	37.0/30.0
ADV 45.0 M430-M		45.0/37.0	90/76	90/75	45.0/37.0
ADV 55.0 M430-M		55.0/45.0	105/90	110/90	55.0/45.0
ADV 75.0 M430-M		75.0/55.0	140/105	150/110	75.0/55.0

2.4 Technical Specification

Function description		Specification indexes
Control nature	Control mode	Control Without PG Vector、V/F Control、Torque control
	Start torque	0.5Hz 150%(SVC) 1.0Hz 150%(V/F)
	Speed adjustable range	1:100 (SVC)
	Stable speed precision	±0.5%Max speed (SVC)

Advanced Systems Baltic OÜ – M430 series products

Product functions	Important function	RPM track、Torque limitation、Multi-step speed、automatic self-adjustment、Slip compensate、PID adjust、Sagged control、Current control、Torque boost、Multi functions input /output terminal
	Frequency given way	Keyboard、upper computer、Analog AI1/AI2、Terminal pulse HDI、Multi-step speed and PLC、PID、The combination of multi-modes and the switch between different modes can be realized.
	Frequency Range	0.00-400.00Hz
	Acc and Dec time	0.1-3600.0s
	Dynamic braking	DC braking start frequency: 0.00-400.00Hz; DC braking current: 0.0-150%; DC braking time: 0.0-50.0s; No need for DC braking start waiting time, realize quickly braking
Special function	Multi functions shortcut key	Multi functions short cut key can be set for these operation: JOG inching、REV and FWD、Clear UP/DOWN set、left shift key display the status、Quickly debug mode
	Multi menu mode	Basic menu mode、Fast menu mode
	Common DC bus	Many frequency inverters Common DC bus、Energy automatic equilibrium
	Swing frequency control	Multi pyramidal wave frequency control
	Counting control	Counting function
Protection function	Over current、Overvoltage、Under volage、Over temp、Phase lack、Overload	
Environment	Operation Place	Indoor, hide sunshine, No dust、Corrosive gas、combustible gas、Oil mist、Water vapor、salinity
	Altitude	<1000m
	Temperature	-10℃~+40℃ (temperature at 40℃~50℃, Drop the forehead use)
	Humidity	<95%RH, No droplet
	Vibration	<5.9m/s ² (0.6g)
	Stock	-20 ℃~60 ℃

2.5 Parts Description

1. 0.75KW-18.5KW Plastic shape description

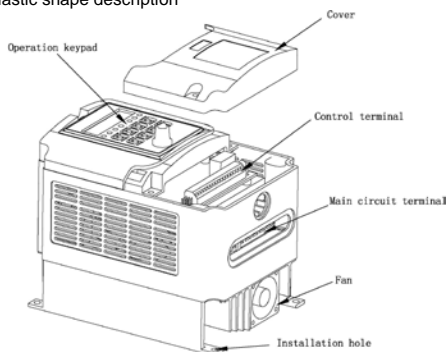

Picture 2—1 0.75KW-18.5KW part's name

2. 22KW-75KW Plastic shell parts

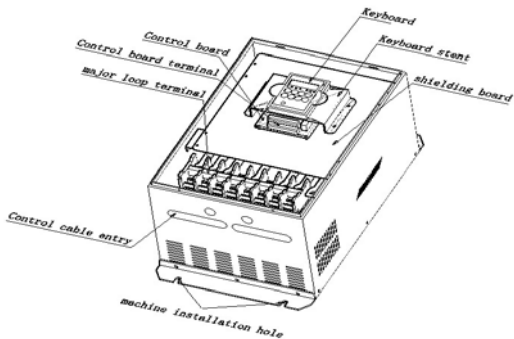

Picture 2—2 22KW-75KW part's name

3. 90KW-345KW Plastic shell parts

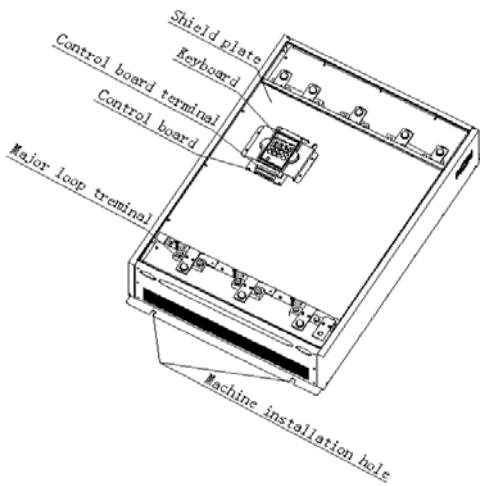

Picture 2—3 90KW-345KW part's name

3. INSTALLATION

3.1 Install Environment

- 1、Temperature: -10°C ~ $+50^{\circ}\text{C}$, if the temperature is above 40°C , please put your inverter in place well ventilized.
- 2、Humidity: $0\% \sim 95\%$ without dew.
- 3、Away from corrosive gas, liquid, oil mist or salt mist.
- 4、No dust or metal powder or debris.
- 5、No vibration and machinery shock.
- 6、No electromagnetism noise (such as welding machine).

3.2 How To Install

For better cooling down the inverter, it is recommended to install the inverter vertically. There are force cooling fan on the bottom of the inverter, enough space must be guaranteed between these cooling fans and its adjacent objects in all directions.

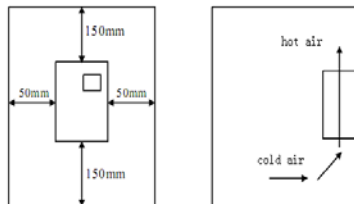

Figure 3—1 Installation Distance

3.3 More than two inverters install

If two inverters installed one onto the other, a guide plate is necessary

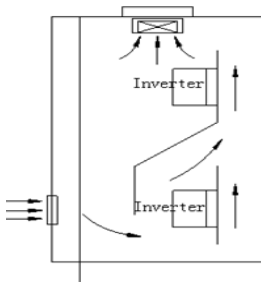

Figure 3—2 Install More Than two Inverters

3.4 External Dimension of frequency inverter

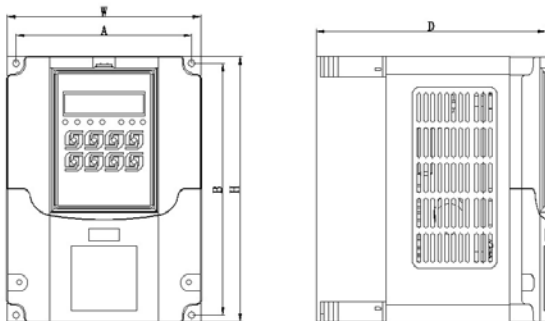

Figure 3—4 0.75KW-22KW External Dimension

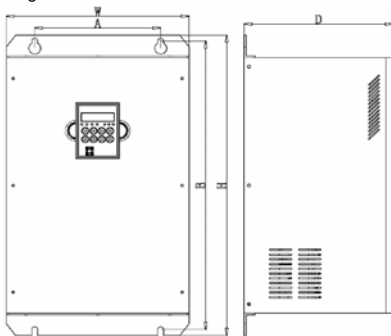
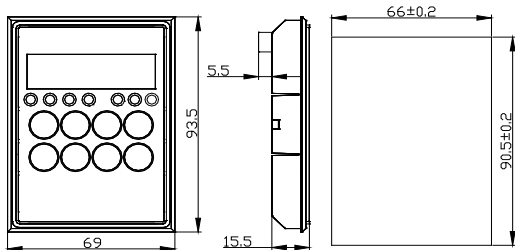

Figure 3—5 30KW-75KW External Dimension

NOTE: Install 30KW to 75KW,pick off the keyboard first then move the cover plate!!
External Dimension and Installation Dimension

(kW)	A (mm)	B (mm)	H (mm)	W (mm)	D (mm)	Hole (mm)
	Installation Dimension		External Dimension			
0.75~2.2	113.5	161.5	170	125	149	5
5.5~11	147.5	238	253	163	175	5.2
15~18.5	205.5	288.5	302	218	216	6.5
22~37	200	486	506	290	236	10
45~75	275	557	582	375	255	10
90~110	320	738	760	460	360	9.5
132~160	400	802	830	560	360	12
185~220	400	1036	1063	650	400	13
250~345	660	1173	1205	824	400	13

3.5 Keyboard Dimension Of Inverter



3-6 External Keyboard's Dimension

3-7 External Keyboard's open pore Dimension

4. WIRING



Warning

- Only qualified electricians are allowed to operate on the safe running of the inverter.
- Never carry out any insulation or voltage withstand tests on the cables connecting with the inverter.
- Even if the inverter is stopped, dangerous voltage is present at the input power lines, DC circuit terminals and motor terminals. Wait for 10 minutes even when the inverter is switched off until it discharge the CHARGE light is off before operation.
- Ground the grounding terminals of the inverter with proper techniques. And the resistor should be less than 10Ω. Otherwise there is danger of electrical shock and fire.
- Do not connect 3-phase power supply to the output terminals (U, V, W) of the inverter, otherwise damage to the inverter may occur.
- Please ensure the right connection between the power supply wires and motor wires. Connect the power supply to the R, S and T terminals and connect motor wires to U, V and W terminals.
- Never do wiring or other operations on the servo drive with wet hands. Otherwise there is danger of electric shock.



Caution

- Verify that the rated voltage of the inverter equals to the voltage of the AC power supply.
- The power wires and motor wires must be permanently fastened and connected.

4.1 Connection of Peripheral Devices

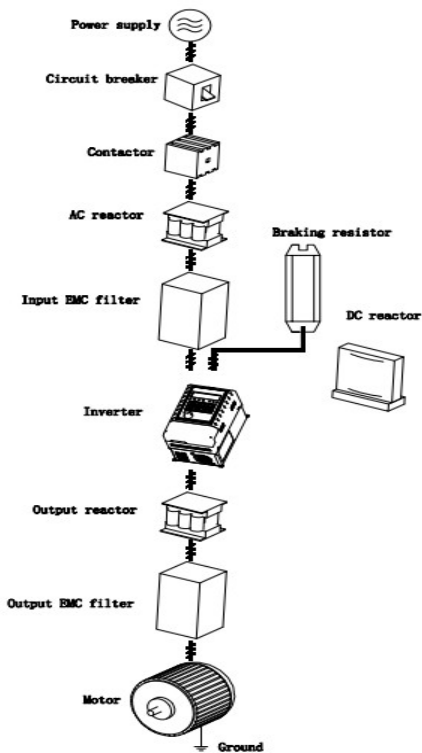

Figure 4.1 Connection of peripheral devices.

4.2 Terminal Configuration

4.2.1 Main Circuit Terminals(AC 380V)

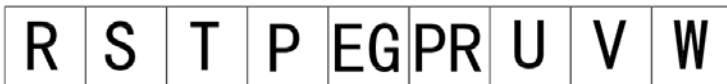

Figure 4-2 Main Circuit Terminals (0.75KW~2.2KW)



Figure 4-3 Main Circuit Terminals (5.5KW~11KW)



Figure 4-4 Main Circuit Terminals (15KW~18.5KW)

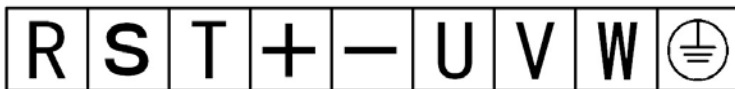

Figure 4-5 Main Circuit Terminals (22KW~37KW)

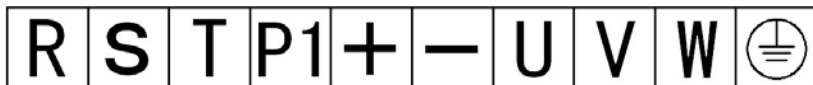

Figure 4-6 Main Circuit Terminals (45KW~75KW)

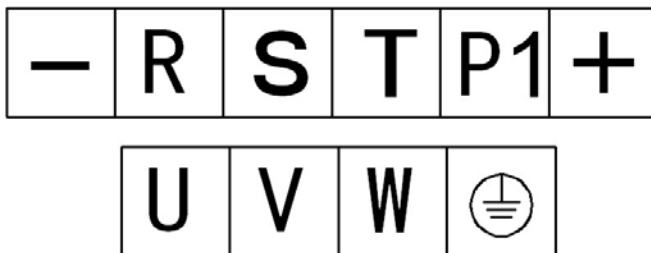

Figure 4—7 Main Circuit Terminals (90KW~110KW)

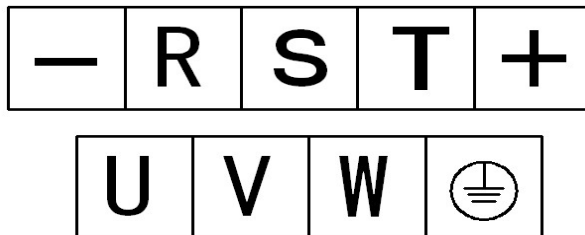

Figure 4—8 Main Circuit Terminals (132KW~345KW)

4.2.2 The function of main circuit terminals are described as followings:

Terminal Symbol	Function Description
R、S、T	Terminals of 3 phase AC input
(+), (-)	Spare terminals of external braking unit (380V up 22kW)
(+), PR	Spare terminals of external braking resistor, 380V down 18.5kW

P1、(+)	Spare terminals of external DC reactor
U、V、W	Terminals of 3 phase AC output
⊖	Terminal of ground

4.2.3 Main Circuit Standard Connect

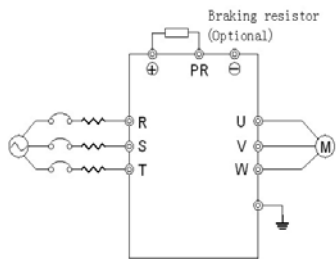

0.75-18.5KW

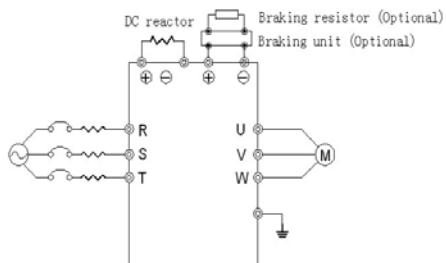

22-345KW

Figure 4—7 Main Circuit Standard Connect

4.2.4 Wiring at input side of main circuit

Circuit breaker

It is necessary to connect a circuit breaker which is compatible with the capacity of inverter between 3ph AC power supply and power input terminals (R, S, and T). The capacity of breaker is 1.5~2 times to the rated current of inverter. See ***Specifications of Breaker, Cable, and Contactor*** for the detail that the capacity of the inverter should between 1.5~2 times of the rated current of the inverter.

Install breaker

Because of the frequency inverter output is higher PWM signal , so have the high frequency current ,please select current sensitivity up 30mA ; if use the universal breaker,please select the sensitivity up 20mA. action time up 0.1 second breaker.

Electromagnetic contactor

In order to cut off the input power effectively

when fault occurs to the system, it is necessary to install a contactor at the input side to control the ON-OFF of the main circuit power supply.

Input AC reactor

In order to prevent the rectifier damage result from the large current when peak pulse input, AC reactor should be installed at the input side. It can also be used to improve the power factor of the input side. For the effective protection, it is recommended to install input reactor for inverters of 380V/110kW (including 110kW).

Install surge suppressor

As the Electromagnetic contactor、solenoid valve、Magnetic Coil、Electromagnetic breaker beside the frequency inverter,please install the surge suppressor.

Input EMC filter

The surrounding device may be disturbed by the cables when the inverter is working. EMC filter can minimize the interference. Just like the following figure.

4.2.5 Wiring at inverter side of main circuit

DC reactor

It is highly recommended to use a DC reactor (optional) with M430 series inverters from 22kw and higher capacities. The DC reactors are for the improvement of power factors and avoidance of damages from high input current to the rectifying components because of the high-capacity transformer. The DC reactor can also cease the damage to the rectifying components which are caused by supply net voltage transient and harmonic waves of the loads..

Braking unit and braking resistor •

M430 series inverters below 18.5kW (380V) are equipped with internal braking unit. In order to dissipate the regenerative energy generated by dynamic braking, the braking resistor should be installed at (+) and PR terminals.

- The wire length of the braking resistor should be less than 5m.

- Please pay attention to safety prevention and smooth ventilation when installing braking resistors because the temperature will rise for the heat releasing.

- The (+) and (-) terminal of the braking units corresponds to the (+) and (-) terminal of the inverter when the external braking unit is connected. Connect braking resistor to the BR1 and BR2 terminal of the braking unit.

- The wiring length between the (+), (-) terminals of the inverter and the (+), (-) terminals of the braking units should be no more than 5m, and the distributing length among BR1 and BR2 and the braking resistor terminals should be no more than 10m.

Note: Be sure that the electric polarity of (+) (-) terminals is right; it is not allowed to connect (+) with (-) terminals directly, otherwise damage or fire may occur.

4.2.6 Wiring of main loop on output side

Connection between inverter and

motor

The output terminals of inverter U, V, W are connected to motor input terminals U, V, and W. When power is on, please check if motor is running forward under forward command, if reverse, please exchange any 2 phases of inverter's terminal U, V, or W.

Never connect power cable to output terminals of inverter

Will damage the internal components of inverter.

Short-circuit on output terminals or grounding is forbidden

Do not touch output terminals directly, or connect the output cable to inverter's housing; there is risk of electric shock and short circuit.

Never use phase-shifting capacitor

Please do not connect phase-shifting lead electrolytic capacitor or LC/RC filter on the output loop, otherwise, it will damage inverter.

Never use electromagnetic switch

Do not connect electromagnetic switch or

electromagnetic contactor to output loop, the action of such components will cause over current or over voltage protection of inverter. Much worse, it will damage inverter's internal components. Please make sure the inverter and motor stops before installing electromagnetic contactor to switch power frequency.

Install reactor on the output side

When the frequency inverter and motor have about 50 meters must install the reactor.

Install noise filter on the output side

Installation of noise filter on output side of inverter can help to reduce inductive interference or radio interference.

4.2.7 Ground Wiring (PE)

In order to ensure safety and prevent electrical shock and fire, terminal PE must be grounded with ground with proper techniques and the grounding resistor is less than 10Ω. The grounding wire should be short with a thick

diameter, and it is better to use multi-wires which have copper core ($>3.5\text{mm}^2$). When multiple inverters need to be grounded, it is recommended to use common grounding wire for the avoidance of loop the ground wire.

4.3 Wiring Control Circuit terminal connect

4.3.1 Precautions

The cable connected to the control terminal should be left away from the main circuit and strong current circuits (including power supply cable, motor cable, relay and contactor connecting cable) at least 20cm and parallel wiring should be avoided. It is suggested to apply perpendicular wiring to prevent inverter malfunction caused by external interference.

4.3.2 Control circuit terminals

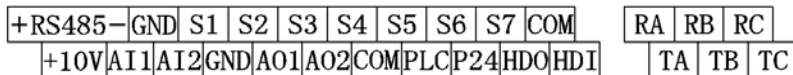

Figure 4—10 Control circuit terminals

4.3.3 Control circuit terminals explain

Terminal	Description
S1~S7	ON-OFF signal input, optical coupling with PW and COM. Input voltage range: 9~30V Input impedance: 3.3kΩ
HDI	High speed pulse or ON-OFF signal input, optical coupling with PW and COM. Pulse input frequency range: 0~50kHz Input voltage range: 9~30V Input impedance: 1.1kΩ
PLC	External power supply. +24V terminal is connected to PW terminal as default setting. If the external power supply is needed, disconnect +24V terminal with PLC terminal and connect PLC terminal with external power supply.
P24	Local power supply of +24V(current: 150mA)
COM	The common terminal of +24V
AI1	Analog input; -10V~10V Input impedance: 20kΩ
AI2	Analog input, 0~10V/ 0~20mA, switched by J2. Input impedance: 10kΩ (voltage input) / 250Ω (current input)
+10V	+10V for the inverter.

Advanced Systems Baltic OÜ — M430 series products

GND	Common ground terminal of analog signal and +10V. GND must be isolated from COM.
HDO	High speed pulse or open collector output terminal. The corresponding common terminal is COM. Output frequency range: 0–50 kHz
AO1, AO2	analog output terminals, of which AO1 can be selected to voltage output or current output by J3; AO2 can be selected to voltage output or current output by J4. Output range: voltage(0~10V) /current (0~20mA)
RA, RB, RC	R relay output, RA common, RB NC, RC NO. Contact capacity: AC250V/3A, DC30V/1A
TA, RB, TC	T relay output, TA common, TB NC, TC NO Contact capacity: AC250V/3A, DC30V/1A
+ RS485 -	485 communication port. 485 differential signal, +,-. Please use twisted pairs and shield cables on the standard communication port.

4.3.4 Multi Functions input and output terminal connect

Use the inside power +24V, External controller is the NPN type sinking current connect mode, as this follow Figure:

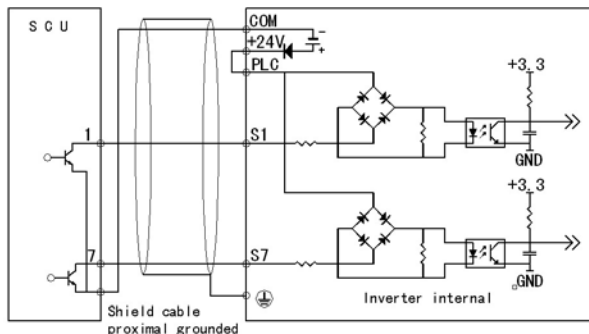

Use the inside power +24V, External controller is the PNP type pull current connect mode, as this follow Figure:

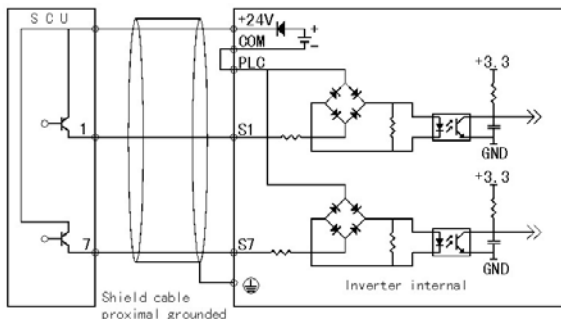

NOTES: pick off the short circuit slice between +24V and PLC terminal, and connect the short

circuit between PLC and COM terminal.

Use the outside power External controller is the NPN type sinking current connect mode, as this follow Figure:

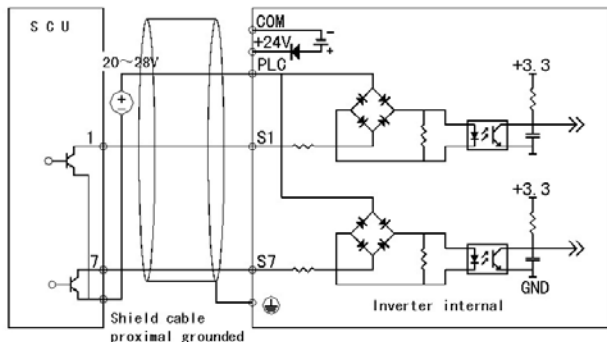

NOTES: pick off the short circuit slice between +24V and PLC terminal Use the outside power External controller is the PNP type pull current connect mode, as this follow Figure:

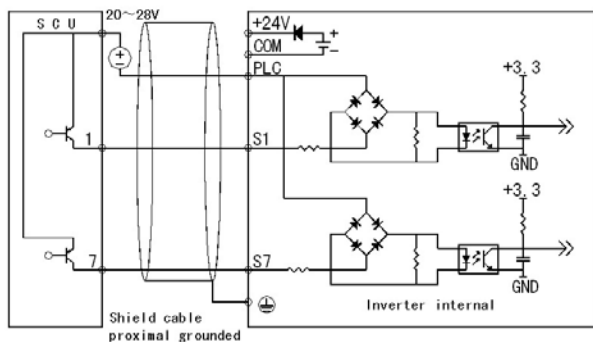

NOTES: pick off the short circuit slice between +24V and PLC terminal

Use the inverter inside power +24V and outside power's multi functions output terminal connect mode:

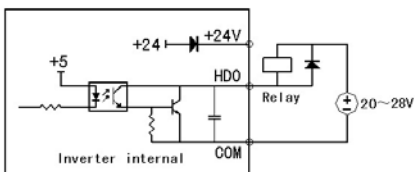
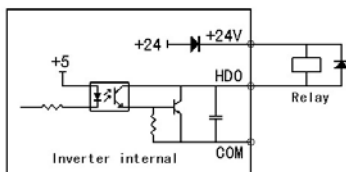

NOTES: Use this connect mode ,if have HDO terminal bad ,please confirm the out connect Diode polarity is right or wrong

4.3.5 JUMPER ON CONTROL BOARD

Jumper	Description
J4	AO2 Voltage、Current (0~10V)/(0~20mA) output change jumper, V and GND short-circuit AO2 output voltage, I and GND short-circuit AO2 output current
J3	AO1 Voltage、Current(0~10V)/(0~20mA) output change jumper , V and GND short-circuit AO1 as output voltage, I and GND short-circuit AO1 as output current.
J2	A12 Voltage (0~10V)/(0~20mA)input change jumper, V and GND short-circuit as input voltage, I and GND short-circuit as input current.

4.3.6 Control loop standard connection diagram

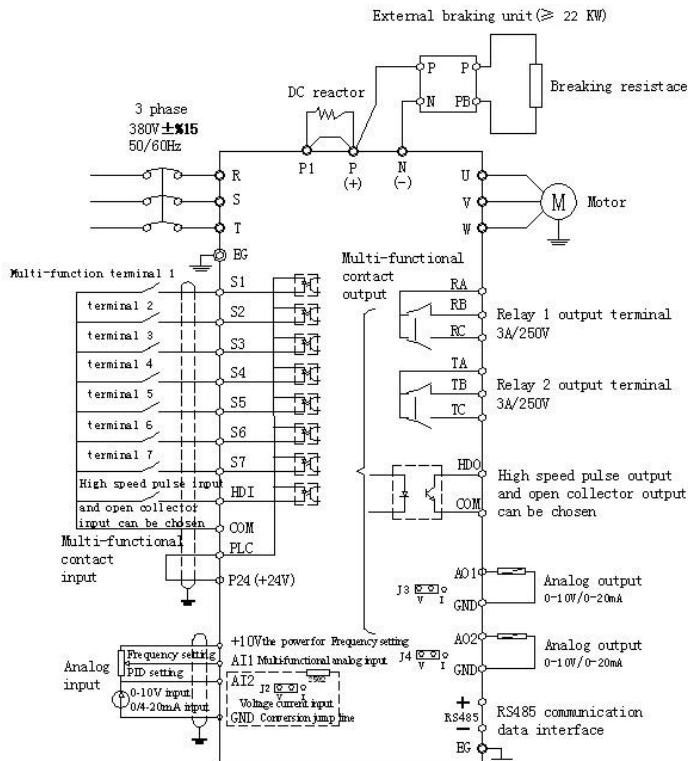

Figure 4-9 Control loop standard connection diagram

4.4 Installation Guideline to EMC Compliance

4.4.1 General knowledge of EMC

EMC is the abbreviation of electromagnetic compatibility, which means the device or system has the ability to work normally in the electromagnetic environment and will not generate any electromagnetic interference to other equipments. EMC includes two aspects: electromagnetic interference and electromagnetic immunity. According to the transmission mode, Electromagnetic interference can be divided into two categories: conducted interference and radiated interference. Conducted interference is the interference transmitted by conductor. Therefore, any conductors (such as wire, transmission line, inductor, capacitor and so on) are the transmission channels of the interference. Radiated interference is the interference transmitted in electromagnetic wave, and the energy is inverse proportional to the square of distance. Three necessary conditions or essentials of electromagnetic interference are: interference source, transmission channel and sensitive receiver. Controlling these factors is right the point of settling the EMC issue. For customers, the solution of EMC problem is mainly originated from transmission channel because of transmitting source and receiver are not changeable.

4.4.2 EMC features of inverter

Like other electric or electronic devices, inverter is not only an electromagnetic interference source but also an electromagnetic receiver. The operating principle of inverter determines that it can generate certain electromagnetic interference noise. At the same time inverter should be designed with certain anti-jamming ability to ensure the smooth working in certain electromagnetic environment. Following is its EMC features:

4.4.2.1 Input current is non-sine wave. The input current includes large amount of high-harmonic waves that can cause electromagnetic interference, decrease the grid power factor and increase the line loss.

4.4.2.2 Output voltage is high frequency PWM wave, which can increase the temperature rise and shorten the life of motor. And the leakage current will also increase, which can lead to the leakage protection device malfunction and generate strong electromagnetic interference to influence the reliability of other electric devices.

4.4.2.3 As an electromagnetic receiver, too strong external interference will cause malfunction and damage. The inverter can not work normally.

4.4.2.4 In the system, EMS and EMI of inverter coexist. Decrease the EMI of inverter can increase its EMS ability.

4.4.3 EMC Installation Guideline

In order to ensure all electric devices in the same system to work smoothly, this section, based on EMC features of inverter, introduces EMC installation process in several aspects of application (noise control, site wiring, grounding, leakage current and power supply filter). The good effective of EMC will depend on the good effective of all of these five aspects.

4.4.3.1 Noise control

All the connections to the control terminals must use shielded wire. And the shield layer of the wire must ground near the wire entrance of inverter. The ground mode is 360 degree annular connection formed by cable clips. It is strictly prohibitive to connect the twisted shielding layer to the ground of inverter, which greatly decreases or loses the shielding effect.

Connect inverter and motor with the shielded wire or the separated cable tray. One side of shield layer of shielded wire or metal cover of separated cable tray should connect to ground, and the other side should connect to the motor cover. Installing an EMC filter can reduce the electromagnetic noise greatly.

4.4.3.2 Site Wiring

Power supply wiring: the power should be separated supplied from electrical transformer. Normally it is 5 core wires, three of which are fire wires, one of which is the neutral wire, and one of which is the ground wire. It is strictly prohibitive to use the same line to be both the neutral wire and the ground wire

Device categorization: there are different electric devices contained in one control cabinet, such as inverter, filter, PLC and instrument etc, which have different ability of emitting and withstanding electromagnetic noise. Therefore, it needs to categorize these devices into strong noise device and noise sensitive device. The same kinds of device should be placed in the same area, and the distance between devices of different category should be more than 20cm.

Wire Arrangement inside the control cabinet: there are signal wire (light current) and power cable (strong current) in one cabinet. For the inverter, the power cables are categorized into input cable and output cable. Signal wires can be easily disturbed by power cables to make the equipment malfunction. Therefore when wiring, signal cables and power cables should be arranged in different area. It is strictly prohibitive to arrange them in parallel or interlacement at a close distance (less than 20cm) or tie them together. If the signal wires have to cross the power cables, they should be arranged in 90 angles. Power input and output cables should not either be arranged in interlacement or tied together, especially when installed the EMC filter. Otherwise the distributed capacitances of its input and output power cable can be coupling each other to make the EMC filter out of function.

4.4.3.3 Grounding

Inverter must be ground safely when in operation. Grounding enjoys priority in all EMC methods because it does not only ensure the safety of equipment and persons, but also is the simplest, most effective and lowest cost solution for EMC problems.

Grounding has three categories: special pole grounding, common pole grounding and series-wound grounding. Different control system should use special pole grounding, and different devices in the same

control system should use common pole grounding, and different devices connected by same power cable should use series-wound grounding.

4.4.3.4 Leakage Current

Leakage current includes line-to-line leakage current and over-ground leakage current. Its value depends on distributed capacitances and carrier frequency of inverter. The over-ground leakage current, which is the current passing through the common ground wire, can not only flow into inverter system but also other devices. It also can make leakage current circuit breaker, relay or other devices malfunction. The value of line-to-line leakage current, which means the leakage current passing through distributed capacitors of input output wire, depends on the carrier frequency of inverter, the length and section areas of motor cables. The higher carrier frequency of inverter, the longer of the motor cable and/or the bigger cable section area, the larger leakage current will occur.

Countermeasure:

Decreasing the carrier frequency can effectively decrease the leakage current. In the case of motor cable is relatively long (longer than 50m), it is necessary to install AC reactor or sinusoidal wave filter at the output side, and when it is even longer, it is necessary to install one reactor at every certain distance.

4.4.3.5 EMC Filter

EMC filter has a great effect of electromagnetic decoupling, so it is preferred for customer to install it.

For inverter, noise filter has following categories:

- Noise filter installed at the input side of inverter;
- Install noise isolation for other equipment by means of isolation transformer or power filter.

4.4.4 The installation complies with following standards:

EN61000-6-4: Electromagnetic Interference Detection on the industrial condition.

EN61800-3: Comply with the electromagnetic radiation standard of EN61800-3 (The second environment). Can comply with the electromagnetic radiation standard of EN61000-6-3(residence) and standard of EN61000-6-4.

5. OPERATION KEYBOARD AND OPERATION

5.1 Keypad Description

5.1.1 Keypad schematic diagram

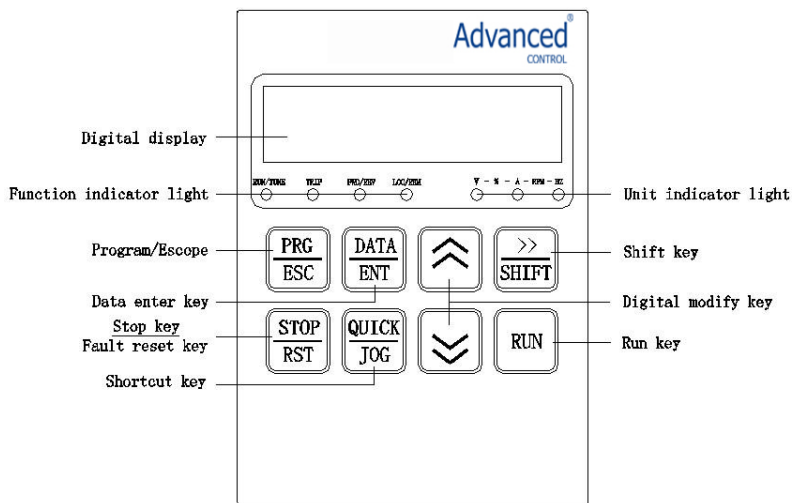











Figure 5—1 Operation Keyboard



5.1.2 Function key description

Key	Name	Function Description
	Program/Escape	Enter or escape from the first level menu,
	Data enter Key	Progressively enter menu and confirm parameters.
	Digital modify key	Progressively increase data or function codes.
	Digital modify key	Progressive decrease data or function codes.
	Shift Key	In parameter setting mode, press this button to select the bit to be modified. In other modes, cyclically displays parameters by right shift
	Run Key	Start to run the inverter in keypad control mode.
	Stop/Reset Key	In running status, restricted by F7.04, can be used to stop the inverter. When fault alarm, can be used to reset the inverter without any restriction.

	<p>Shortcut Key</p>	<p>Determined by Function Code F7.03:</p> <ul style="list-style-type: none"> 0: Display status switching 1: Jog operation 2: Switch between forward and reverse 3: Clear the UP/DOWN settings. 4: Quick debugging mode
 <p style="text-align: center;">+</p> 	<p>Combination Key</p>	<p>Pressing the RUN and STOP/RST at the same time can achieve inverter coast to stop.</p>

5.1.3 Indicator light description

1) Function Indicator Light Description

Unit indicator	Description
	<p>Extinguished: stop status</p> <p>Flickering: parameter auto tuning status</p> <p>Light on: operating status</p>
	<p>Extinguished: forward operation</p> <p>Light on: reverse operation.</p>

Unit indicator	Description
LOC/REM	Extinguished: keypad control Flickering: terminal control Light on: communication control
TRIP	Extinguished: normal operation status Flickering: overload pre-warning status

2) Unit Indicator Light Description:

Unit indicator	Description
Hz	Frequency unit
A	Current unit
V	Voltage unit
RPM	Rotating speed unit
%	Percentage

3) Digital Display:

Have 5 digit LED , which can display all kinds of monitoring data and alarm codes such as reference frequency, output frequency and so on.

5.2 Operation Process

5.2.1 Parameter setting

Three levels of menu are:

- Function code group (first-level);
- Function code (second-level);
- Function code value (third-level).

Remarks:

Press either the **PRG/ESC** or the **DATA/ENT** can return to the second- level menu from the third- level menu. The difference is: pressing **DATA/ENT** will save the set parameters into the control panel, and then return to the second- level menu with shifting to the next function code automatically; while pressing **PRG/ESC** will directly return to the second-class menu without saving the parameters, and keep staying at the current function code.

- This function code is not modifiable parameter, such as actual detected parameter, operation records and so on;
- This function code is not modifiable in running

status, but modifiable in stop status.

5.2.2 Fault reset

If fault occurs to the inverter, it will inform the related fault information. User can use **STOP/RST** or according terminals determined by F5 Group to reset the fault. After fault reset, the inverter is in stand-by state. If user does not reset the inverter when it is in fault state, the inverter will be in operation protection state, and can not run.

5.2.3Motor parameters auto tuning

Input right nameplate parameter of the motor before the running of the inverter. M430 series inverter matches the standard motor parameter according to the nameplate. M430 series inverter support parameter auto tune to improve the control permanence.

The procedure of motor parameter auto tuning is as follows:

Firstly, choose the keypad command channel as the operation command channel (F0.01).

And then input following parameters according to

the actual motor parameters:

F2.01: motor rated power.

F2.02: motor rated frequency;

F2.03: motor rated speed;

F2.04: motor rated voltage;

F2.05: motor rated current;

Set F0.16 to be 1, and for the detail process of motor parameter auto tuning, please refer to the description of Function Code F0.16. And then press **RUN** on the keypad panel, the inverter will automatically calculate following parameter of the motor. See the instruction of F0.16 for the detailed information.

F2.06: motor stator resistance;

F2.07: motor rotor resistance;

F2.08: motor stator and rotor inductance;

F2.09: motor stator and rotor mutual inductance;

F2.10: motor current without load;

Then motor auto tuning is finished.

The keypad will display **TUN-1** and **TUN-2** during auto tune. When the keypad displays **-END-**, the parameter auto tune has been finished.

Note: The motor should be de-coupled from the load; otherwise, the motor parameters obtained by auto tuning may be incorrect.

5.2.4 Password setting

M430 series inverter provides password protection function to users. Set F7.00 to gain the password and the password protection becomes effective instantly after quitting from the function code editing state. Press **PRG/ESC** again to the function code editing state, **-----** will be displayed. Unless using the correct password, the operators cannot enter it. Set F7.00 to 0 to cancel password protection function and the password cannot protect the parameters in the quick menu.

5.2.5 Shortcut menu setting

Shortcut menu, in which parameters in common use can be programmed, provides a quick way to view and modify function parameters. In the shortcut menu, a parameter being displayed as "hF0.11" means the function parameter F0.11. Modifying parameters in the shortcut menu has the same effect as doing at normal programming status.

5.3 Running State





5.3.1 Power-on initialization

Firstly the system initializes during the inverter power-on, and LED displays “Advanced Control”. After the initialization is completed, the inverter is in stand-by status





5.3.2 Stand-by

In stop or running status, multi-status parameters can be displayed. And these function can be choose to display through function code F7.06 and F7.07 (running parameters) and F7.08(stop parameters) at the binary bits. See the description of F7.06, F7.07 and F7.08 for detailed definition.

In stop status, there are ten stopping parameters which can be chosen to display or not. They are: reference frequency, DC bus voltage, ON-OFF input status, open collector output status, PID setting, PID feedback, analog input AI1 voltage, analog input AI2 voltage, HDI frequency, step number of simple PLC and multi-step speed. Whether or not to display depends on setting the

corresponding binary bit of F7.08. Press the   to scroll through the parameters in right order. Press  +  to scroll through the parameters in left order.

5.3.3 Operation

In running status, there are nineteen running parameters which can be chosen to display or not. They are: running frequency, reference frequency, DC bus voltage, output voltage, output current, rotating speed, line speed, output power, output torque, PID setting, PID feedback, ON-OFF input status, open collector output status, length value, count value, step number of PLC and multi-step speed, voltage of AI1, voltage of AI2, high speed pulse input HDI frequency. Whether or not to display depends on setting the corresponding bit of F7.06, F7.07. Press the   to scroll through the parameters in right order. Press  +  to scroll through the parameters in left order.

5.3.4 Fault

In fault status, inverter will display parameters of

STOP status besides parameters of fault status.

Press the **▶ /SHIFT** to scroll through the parameters in right order . Press **DATA/ENT** + **QUICK/JOG** to scroll through the parameters in left order.

M430 series inverter offers a variety of fault information. For details, see inverter faults and their troubleshooting.

5.4 Shortcut Menu

Shortcut menu provides a quick way to view and modify function parameters.

Setting the F7.03 to 4, the press **QUICK/JOG**, the inverter will search the parameter which is different from the factory setting, save these parameters to be ready for checking. The buffer length of shortcut menu is 32. So when the record data beyonds to 32, can not display the overlength part. Press **QUICK/JOG** will be the shortcut debugging mode. If the **QUICK/JOG** displays "NULLF", It means the parameters is the same with the factory setting. If want to return to last display, press **QUICK/JOG**.

6.DETAILED FUNCTION DESCRIPTION

F0 Group Basic Function

Function code	Name	Setting range
F0.00	Speed Control model	0~2 【0】

This parameter is used to select the speed control mode of the inverter.

0: V/F control: It is only suitable for motor commissioning cases where needs not high accuracy or the cases where one inverter drives multiple motors.

1: Sensorless vector control: It is only suitable for motor commissioning cases or the cases where needs not high accuracy. This mode is applied in the universal high performance cases where the pulse encoder is not installed or the cases where requires high torque at low speed, high speed accuracy, and quicker dynamic response, such as machine tool, injection molding machine, centrifugal machine and wire-drawing machine,

etc. One inverter only drives one motor.

2. Torque control (sensorless vector control): It is suitable for the application with low accuracy torque control, such as wired-drawing.

Note:

Set right nameplate parameters of the motor and encoder parameters when selecting vector control mode and complete the parameters auto tune before running to get the right motor parameters. Only proper motor parameter can improve the high performance of vector control.

Adjust F3 group can optimize the performance of vector control.

Function code	Name	Setting range
F0.01	Run command source	0~2 【0】

The control commands of inverter include: start, stop, forward run, reverse run, jog, and fault reset and so on.

0: Keypad (LED extinguished);

Both **RUN** and **STOP/RST** key are used for running command control. If Multifunction key **QUICK/JOG** is set as FWD/REV switching function (F7.03 is set to 2), it will be used to change the rotating orientation. **In running status, pressing **RUN** and **STOP/RST** in the same time will cause the inverter coast to stop.**

1: Terminal (LED flickering)

The operation, including forward run, reverse run, forward jog, reverse jog etc. can be controlled by multifunctional input terminals.

2: Communication (LED lights on)

The operation of inverter can be controlled by host through communication.

Function code	Name	Setting range
F0.02	Keypad and terminal UP/DOWN setting	0~3 【0】

The frequency can be set by **▲**, **▼** and terminal UP/DOWN. This setting method have the highest and it can be combined with setting channel. It is used to adjust the output frequency during the commissioning of controlling system.

0: valid, and the value can be saved when the inverter is powered off. The frequency command can be set and the value can be saved after the inverter is powered off and it will combine with the current frequency when it is repowered on.

1: valid, and the value can not be saved when the inverter is powered off. The frequency command can be set but the value can not be saved after the inverter is powered off

2: invalid, the function of **▲**, **▼** and terminal UP/DOWN is invalid, and the setting will be cleared automatically.

3: valid during running. The function of **▲**, **▼** and terminal UP/DOWN is valid during running and the setting will be cleared automatically when the inverter stops.

Note: When the factory setting is restored, the value of keypad and UP/DOWN will be cleared.

Function code	Name	Setting range
F0.03	Maximum frequency	10.00~400.00 Hz 【50.00Hz】

This parameter is used to set the Max. Output frequency of the inverter. It is the basic of frequency setting and the speed of ACC/DEC.

Please pay attention to it.

Function code	Name	Setting range
F0.04	Upper frequency limit	F0.05~F0.03 【50.00Hz】

This is the upper limit of the output frequency and it will be less than or equal to the Max. Output frequency.

Function code	Name	Setting range
F0.05	Lower frequency limit	0.00~F0.04 【0.00Hz】

This is the lower limit of the output frequency of the inverter.

This parameter can be selected by function code F1.12. If the setting frequency is lower than the upper limit, the inverter will run, stop or hibernate at the lower limit frequency. The Max. Output frequency \geq Upper limit of the frequency \geq Lower limit of the frequency.

Function code	Name	Setting range
F0.06	Keypad setting frequency	0.00~F0.03 【50.00Hz】

When Frequency A command source is set to be Keypad, this parameter is the initial value of inverter reference frequency.

Function code	Name	Setting range
F0.07	Frequency A command source	0~7 【0】

Select Frequency A command input channel and there are 8 main given frequency channels.

0: Keypad: Please refer to description of F0.06

Set the frequency by keypad through modifying F0.06.

1: AI1

2: AI2

Set the frequency through analog input terminals. M430 series inverters provide 2 ways analog input terminal in its standard configuration, of which AI1 is -10V~10V voltage input; AI2 is 0~10V/0(4)~20mA input. The current/voltage can be shifted by J2.

Note: when AI2 selects 0~20mA input, 20mA corresponds to 5V.

100.0% of analog input corresponds to the Max. Frequency (function code F0.03), -100.0% corresponds to the Max. Frequency in reverse (function code F0.03).

3: HDI

The reference frequency is set by high speed pulse input. M430 series inverters provide 1 way HDI input in its standard configuration.

Pulse specification: pulse voltage range 15~30V, and pulse frequency range 0.0~50.0 kHz. 100% of the setting in pulse corresponds to maximal

frequency, while -100% corresponds with minus maximal frequency.

Note: pulse can only be input through multi-function terminal HDI. And set F5.00=0 to select the function of HDI as “setting input”.

4. Simple PLC

The inverter will run at simple PLC when selecting this frequency setting method. It is necessary to set the parameter of FA group to determine the given frequency, running direction and each ACC/DEC time. Please refer to the instruction of FA group carefully.

5. Multi-stage speed

The inverter will run at multi-stage speed when selecting this frequency setting method. The reference frequency is determined by F5 and FA group. If F0.07 is not multi-stage speed setting, then the multi-stage setting has the priority which is lower than the priority of jogging. Only stage 1~15 can be set when multi-stage setting has the priority. So stage 1~15 can be set when F0.07 is multi-stage speed setting.

6. PID control

The running mode is procedure PID control

when selecting this parameter. It is necessary to set F9 group. The reference frequency is the result of PID adjustment. For details, please refer to description of F9 group

7. Remote Communication

The frequency command is given by the upper monitor through communication given. Please refer to MODBUS communication protocol in chapter 7. The reference frequency is set through RS485. For details, please refer to Modbus protocol in Chapter7.

Function code	Name	Setting range
F0.08	Frequency B command source	0~2 【0】

0: AI1

1: AI2

2: HDI

When B frequency command is the only frequency reference channel, its application is the same with A frequency command. For details, please refer to

F0.07.

Function code	Name	Setting range
F0.09	Scale of frequency B command	0~1 【0】

0 : Maximum output frequency, 100% of B frequency setting corresponds to the maximum output frequency

1: A frequency command, 100% of B frequency setting corresponds to the maximum output frequency. Select this setting if it needs to adjust on the base of A frequency command

Note: If set AI2 to be 0~20mA input, the relative voltage of 20mA is 5V. F0.09 is used when the frequency B is superimposed.

Function code	Name	Setting range
F0.10	Frequency command selection Setting	0~3 【0】

0: Only frequency command source A is active.

1: Only frequency command source B is active.

2: Both Frequency command source A and B are active.

Reference frequency = reference frequency A + reference frequency B.

3: Both Frequency command source A and B are active.

Reference frequency = Max (reference frequency A, reference frequency B).

Note: Combination (0, 1 and 2) can be switched by F5 group.

Function code	Name	Setting range
F0.11	Acceleration time 0	0.1~3600.0s 【Depend on model】
F0.12	Deceleration time 0	0.1~3600.0s 【Depend on model】

Acceleration time is the time of accelerating from 0Hz to maximum frequency (F0.03). Deceleration time is the time of decelerating from maximum

frequency (F0.03) to 0Hz. Please refer to following figure.

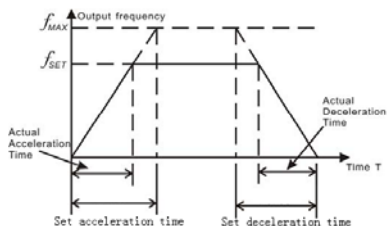

Figure 6.1 Acceleration and deceleration time

When the reference frequency is equal to the maximum frequency, the actual acceleration and deceleration time will be equal to actual setting.

When the reference frequency is less than the maximum frequency, the actual acceleration and deceleration time will be less than actual setting.

The actual acceleration (deceleration) time = setting ACC/DEC time* reference frequency/ maximum frequency.

1st group: F0.11, F0.12

2nd group: F8.00, F8.01

3rd group: F8.02, F8.03

4th group: F8.04, F8.05.

The acceleration and deceleration time can be selected by combination of multifunctional ON-OFF input terminals

Function code	Name	Setting range
F0.13	Running direction selection	0~3 【0】

0: Runs at the default direction, the inverter runs in the forward direction.

1: Runs at the opposing direction, the inverter runs in the reverse direction. This effect equals to the shifting the rotation direction by adjusting either two of the motor wires.

Note: If the parameters are restored, the running direction will be back to its original status.

2: Forbid to run in reverse direction: It can be used in some special cases if the reverse running is disabled.

Function	Name	Setting range
----------	------	---------------

code		
F0.14	Carrier frequency	1.0~15.0kHz 【dependent on the motor type】

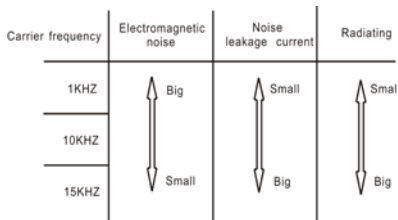

Figure 6.2 Effect of carrier frequency.

The following table is the relationship between power rating and carrier frequency.

Model	Carrier F	Highest	Lowest	Factory
		Carrier F (kHz) (kHz)	Carrier F (kHz)	setting (kHz)
0.75~15kW		15	1.0	8
18.5~75kW		8	1.0	4
90~645kW		6	1.0	2

The advantage of high carrier frequency: ideal

current waveform, little current harmonic wave and motor noise.

The disadvantage of high carrier frequency: increasing the switch loss, increasing inverter temperature and the impact to the output capacity.

The inverter needs to derate on high carrier frequency. At the same time, the leakage and electrical magnetic interference will increase.

Applying low carrier frequency is contrary to the above, too low carrier frequency will cause unstable running, torque decreasing and surge.

The manufacturer has set a reasonable carrier frequency when the inverter is in factory. In general, users do not need to change the parameter.

When the frequency used exceeds the default carrier frequency, the inverter needs to derate 20% for each additional 1k carrier frequency.

Function code	Name	Setting range
F0.15	AVR function	0~2 【1】

AVR function is the output voltage automatic adjustment function. When AVR is invalid, the

output voltage will change with the input voltage (or DC bus voltage); when AVR is valid, the output voltage won't change with the input voltage (or DC bus voltage). The range of output voltage will keep constant. If the site requirement is not met, AVR function can be canceled to shorten the DEC time.

Function code	Name	Setting range
F0.16	Motor parameters auto tuning	0~2 【0】

0: No action: Forbidding auto tuning.

1: Rotation auto tuning:

Input right parameters of the motor nameplate (F2.01–F2.05) and do not connect any load to the motor before performing auto tuning and ensure the motor is in static and empty status. Otherwise the parameters detected by auto tuning will be incorrect.

Set the proper acceleration and deceleration time (F0.11 and F0.12) according to the motor inertia before performing auto tuning. Otherwise it may cause over-current and over-voltage fault during

auto tuning.

Set F0.16 to be 1 then press the **DATA/ENT**. LED will display “-TUN-” and flickers. During “-TUN-” is flickering, press the **PRG/ESC** to exit auto tuning. Press **RUN** to start the auto tuning, and the LED will display “TUN-0” and “TUN-1” “RUN/TUNE” light will flicker. After a few minutes, LED will display “-END-”. That means the auto tuning is finished and return to the stop status. When “-TUN-” flickers, pressing **PRG/ESC** can escape from the parameter auto tune. During the auto tuning, press the **STOP/RST** will stop the auto tune.

Note: Only keypad can control the auto tuning. F0.12 will restore to 0 automatically when the auto tuning is finished.

2: Static auto tuning:

- ◆ If it is difficult to disconnect the load, static auto tuning is recommended.
- ◆ The operation process is the same as rotation auto tuning except step c.

Function	Name	Setting range
----------	------	---------------

code		
F0.17	Restore parameters	0~2 【0】

0: No action

1: Inverter restores all parameters to factory setting.

2: Inverter clear all fault records.

This function code will restore to 0 automatically when complete the function operation.

F1 Group Start and Stop Control

Function code	Name	Setting range
F1.00	Start Mode	0~2 【0】

0: Start directly: Start the motor at the starting frequency directly.

1: DC braking and start: Inverter will output DC current firstly and then start the motor at the starting frequency. Please refer to description of F1.03 and F1.04. It is suitable for the motor which have small inertia load and may reverse rotation

when start.

2: Speed tracking and start: Inverter detects the rotation speed and direction of motor, then start running to its reference frequency based on current speed. This can realize smooth start of rotating motor with big inertia load when instantaneous power off.

Note: It only applies on the inverter of 11kW and above.

Function code	Name	Setting range
F1.01	Starting frequency	0.00~10.00 【0.00Hz】
F1.02	Hold time of starting frequency	0.0~50.0s 【0.0s】

Set proper starting frequency can increase the starting torque. The inverter runs from the starting frequency and after the keeping time of the starting frequency, the inverter will accelerate to the aimed frequency during the ACC time. If the reference frequency is less than starting frequency, the inverter will be at stand-by status. The

indicator of RUN/TUNE lights on, inverter has no output. The starting frequency could be less than the lower frequency limits. The starting frequency takes no effect during FWD/REV switching

Function code	Name	Setting range
F1.03	DC Braking current before start	0.0~150.0% 【0.0%】
F1.04	DC Braking time before start	0.0~50.0s 【0.0s】

During the DC braking before F1.03, the increased current is the percentage to the rated current of the inverter.

DC braking is invalid when F1.04 is set to be 0.

The bigger the DC braking current, the greater the braking torques.

Function code	Name	Setting range
F1.05	Acceleration / Deceleration mode	0~1 【0】

The frequency changing method during the running and starting of the inverter.

0: Linear

Output frequency will increase or decrease with fixed acceleration or deceleration time.

1: Reserved

Function code	Name	Setting range
F1.06	Stop mode	0~1 【0】

0: Deceleration to stop

When the stop command takes effect, the inverter decreases the output frequency and the defined deceleration time till stop.

1: Coast to stop

When the stop command takes effect, the inverter blocks the output immediately. The motor coasts to stop by its mechanical inertia.

Function code	Name	Setting range
F1.07	Starting frequency of DC braking	0.00~F0.03 【0.00Hz】

F1.08	Waiting time before DC braking	0.0~50.0s 【0.0s】
F1.09	DC braking current	0.0~150.0% 【0.0%】
F1.10	DC braking time	0.0~50.0s 【0.0s】

Starting frequency of DC braking: Start the DC braking when running frequency reaches starting frequency determined. Starting frequency of DC braking is 0 and the DC braking is invalid. The inverter will stop in the defined DEC time.

Waiting time before DC braking: Inverter blocks the output before starting the DC braking. After this waiting time, the DC braking will be started so as to prevent over-current fault caused by DC braking at high speed.

DC braking current: The value is the percentage of rated current of inverter. The bigger the DC braking current is, the greater the braking torque is.

DC braking time: The time used to perform DC braking. If the time is 0, the DC braking will be

invalid.

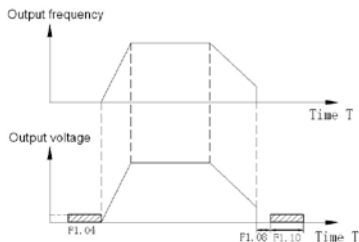

Figure 6.3 DC braking diagram.

Function code	Name	Setting range
F1.11	Dead time of FWD/REV	0.0~3600.0s 【0.0s】

Set the hold time at zero frequency in the transition between forward and reverse running.

It is shown as following figure:

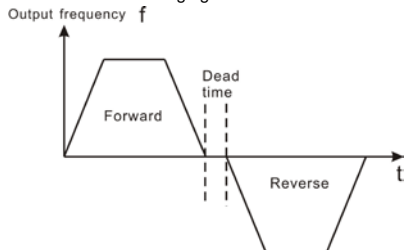

Figure 6.4 FWD/REV dead time diagram.

Function code	Name	Setting range
F1.12	Action when running frequency is less than lower frequency limit	0~2 【0】

This function code is used to define the running state when the setting frequency is lower than the lower frequency limit.

0: Running at the lower frequency limit: The inverter runs at a frequency which is lower than the lower frequency limit

1: Stop: This parameter is used to prevent motor running at low speed for a long time.

2: Stand-by: Inverter will Coast to stop when the running frequency is less than the lower frequency limit. When the reference frequency is higher than or equal to the lower frequency limit again, the inverter will start to run automatically.

Note: the function is only valid when the lower

frequency limit is above 0.

Function code	Name	Setting range
F1.13	Delay time for restart	0.0~3600.0s 【0】

When F1.12=2, only setting frequency bigger again or as the lower limit 's time exceed the value which F1.13 setting,the frequency inverter begin start

Note: when F1.12 as 2 valid

Function code	Name	Setting range
F1.14	Restart after power off	0~1 【0】

0: Disabled: Inverter will not automatically restart when power on again until run command takes effect.

1: Enabled: When inverter is running, after power off and power on again, if run command source is key control or communication control, inverter will automatically restart after delay time determined by F1.15

Note: This function only up 15KW type have, please be cautious.

Function code	Name	Setting range
F1.15	Waiting time of restart	0.0~3600.0s 【0.0s】

Note: Valid when F1.14=1

Function code	Name	Setting range
F1.16	Terminal function ermined when power is on	0~1 【0】

This function only takes effect if run command source is terminal control.

If F1.16 is set to be 0, when power on, inverter will not start even if FWD/REV terminal is active, until FWD/REV terminal disabled and enabled again.

If F1.16 is set to be 1, when power on and FWD/REV terminal is active, inverter will start automatically.

Note:

This function may cause the inverter restart

automatically, please use it with cautious.

Function code	Name	Setting range
F1.17~ F1.19	Reversed	

F2 Group Motor Parameters

Function code	Name	Setting range
F2.00	Inverter model	0~1 【depend on model】

0:General purpose:Applicable to constant torque load.

1: Pump application: Applicable to constant power load.

M430 series inverters apply the manner of general purpose/pump application unification, which means the power of the motor used for general purpose is lower than the power of the motor used for pump application for one gear

The factory setting of the inverter is pump application. If general purpose is selected, it is necessary to set the function code to 0 and reset

the motor parameters of F2. For example, the factory setting of ADV 30.0 M430-M is 30kW for pump application. If it is necessary to change it to 22kW for general purpose, set F2.00 to 0 and reset the motor parameters of F2.

Function code	Name	Setting range
F2.01	Motor rated power	0.4~3000.0kW 【 Depend on model】
F2.02	Motor rated frequency	0.01Hz~F0.03 【 50.00Hz】
F2.03	Motor rated speed	0~36000rpm 【 1460rpm】
F2.04	Motor rated voltage	0~800V 【 Depend on model】
F2.05	Motor rated current	0.8~6000.0A 【 Depend on model】

Note: In order to achieve superior performance, please set these parameters according to motor nameplate, and then perform auto tuning.

The inverter provides parameters auto tune. Correct parameters auto tune is from the right setting of parameter of motor. The power rating of inverter should match the motor. If the bias is too big, the control performances of inverter will be deteriorated distinctly.

Reset F2.01 can initialize F2.06~F2.10 automatically.

Function code	Name	Setting range
F2.06	Motor stator resistance	0.001~65.535Ω 【Depend on model】
F2.07	Motor rotor resistance	0.001~65.535Ω 【Depend on model】
F2.08	Motor leakage inductance	0.1~6553.5mH 【Depend on model】
F2.09	Motor mutual inductance	0.1~6553.5mH 【Depend on model】
F2.10	Current without load	0.1~6553.5A 【Depend on model】

After auto tuning, the value of F2.06—F2.10 will be automatically updated. These parameters are the basic parameters for high performance V/F control which have direct impact to the control performance.

Note: Do not change these parameters; otherwise it may deteriorate the control performance of inverter.

F3 Group Vector Control

Function code	Name	Setting range
F3.00	ASR proportional gain Kp1	0~100 【20】
F3.01	ASR integral time Ki1	0.01~10.00s 【0.50s】
F3.02	ASR switching lower frequency	0.00~F3.05 【5.00Hz】
F3.03	ASR proportional gain Kp2	0~100 【15】

Function code	Name	Setting range
F3.04	ASR integral time K_i2	0.01~10.00s 【1.00s】
F3.05	ASR switching lower frequency	F3.02~F0.03 【10.00Hz】

less than F3.02. F3.03 and F3.04 only take effect when output frequency is greater than F3.05. When output frequency is between F3.02 and F3.05, K_p and K_i are proportional to the bias between F3.02 and F3.05. For details, please refer to following figure.

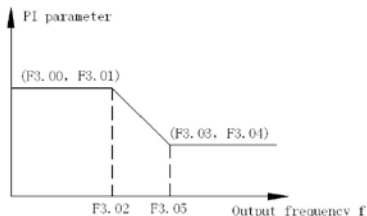

Figure 6-6 PI parameter diagram.

The system's dynamic response can be faster if the proportion gain K_p is increased; However, if K_p is too large, the system tends to

oscillate.

The system dynamic response can be faster if the integral time K_i is decreased;

However, if K_i is too small, the system becomes overshoot and tends to oscillate.

The adjustment procedure is as follow:

- ◆ Increase the proportional gain (K_p) as far as possible without creating oscillation.
- ◆ Reduce the integral time (K_i) as far as possible without creating oscillation.

Function code	Name	Setting range
F3.06	Slip compensation rate of VC	50%~200% 【100%】

The parameter is used to adjust the slip frequency of vector control and improve the precision of speed control. Properly adjust this parameter can effectively restrain the static speed bias.

Function code	Name	Setting range
F3.07	Torque upper limit	0.0~200.0% 【Depend on model】

Note:

- **100% setting corresponding to rated current. General purpose : 150.0% ;**

Pump application: 120.0%.

- **Under torque control, F3.07 and F3.09 are all related with torque setting.**

Function code	Name	Setting range
F3.08	Torque setting source	0~5 【0】

0: Keypad (F3.09)

1:A11

2:A12

3: HDI

4:Multi-step speed

5:Communication

1~5: Torque control is valid, which defines the torque setting source. When the torque setting is minus, the motor will reverse.

Under speed control mode, output torque matches load torque automatically, but limited by F3.07. If the load is above the set upper limit of the torque,

the output torque of the inverter will be limited, and the rotation speed of the motor will change automatically.

Under the torque control mode, the inverter will output torque at the set command, but the output frequency is limited by the upper or lower limit.

When the set torque is above the load torque, the output frequency of the inverter will raise to the upper limit frequency; if the set torque is below the load torque, the output frequency of the inverter will decrease to the lower limit frequency. If the output frequency of the inverter is limited, the output torque will be different from the set torque.

Note:

- **Speed control and torque control can be switched by using multi-function input terminals.**

- **1~5: 100% corresponding to twice of rated current of inverter.**

- **When inverter decelerate to stop, Torque control model is switched to speed control mode automatically**

Function code	Name	Setting range
F3.09	Keypad torque setting	-200.0~200.0% 【50.0%】
F3.10	Upper frequency setting source	0~5 【0】

0: Keypad (F0.04)

1:Al1

2:Al2

3:HDI

4:Multi-step speed

5:Communication

Note: 1~4 100% Corresponds to maximum frequency.

F4 Group V/F Control

Valid when F0.00=0.

Function code	Name	Setting range
F4.00	V/F curve selection	0~4 【0】

0: Linear V/F curve. It is applicable for normal constant torque load.

1: Multidots curve. It can be defined through setting (F4.03~F4.08).

2~4: Torque_stepdown curve. It is applicable for variable torque load, such as blower, pump and so on. Please refer to following figure.

Note: V_b = Motor rated voltage F_b = Motor rated frequency.

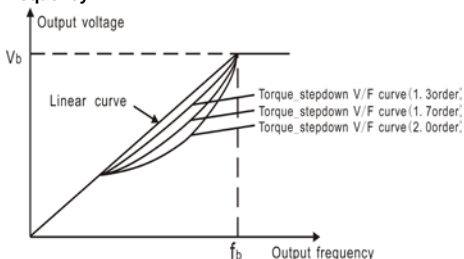

Figure 6-7 V/F Curve

Function code	Name	Setting range
F4.01	Torque boost	0.0~10.0% 【0.0%】
F4.02	Torque boost cut-off	0.0~50.0% 【20.0%】

Torque boost will take effect when output frequency is less than cut-off frequency of torque

boost (F4.02). Torque boost can improve the torque performance of V/F control at low speed.

The value of torque boost should be determined by the load. The heavier the load, the larger the value is. If the boost is too large, the motor will run in exciting. The efficiency of the motor decreases as the current of the inverter increases and the motor increase the heat-releasing.

When the torque boost is set to 0.0%, the inverter is in the automatic torque boost state.

Cut-off point of torque boost: the torque boost is valid under this point, and the torque boost is invalid when exceeding this set frequency.

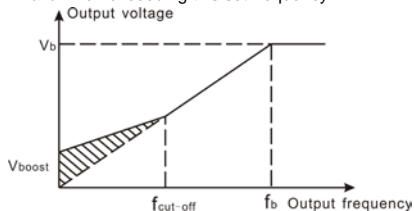

Figure 6-8 Torque boost by hand

Function code	Name	Setting range
F4.03	V/F	0.00~F4.05

Function code	Name	Setting range
	frequency1	【0.00Hz】
F4.04	V/F voltage 1	0.0~100.0% 【0.0%】
F4.05	V/F frequency 2	F4.03~F4.07 【0.00Hz】
F4.06	V/F voltage 2	0.0~100.0% 【0.0%】
F4.07	V/F frequency3	F4.05~F2.02 【0.00Hz】
F4.08	V/F voltage3	0.0~100.0% 【0.0%】

F4.03~F4.08 are used to set the user-defined V/F curve. The value should be set according to the load characteristic of motor.

Note:

- $0 < V1 < V2 < V3 < \text{rated voltage}$.
- $0 < f1 < f2 < f3 < \text{rated frequency}$.
- The voltage corresponding to low frequency should not be set too high, otherwise it may cause motor overheat or inverter fault.

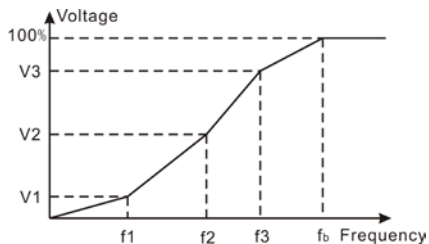

Fb= Motor rated frequency (F2.02)

N= Motor rated speed (F2.03)

P= Motor poles

Function code	Name	Setting range
F4.10	energy saving selection	0~1 【0】

Figure 6.9 V/F curve setting diagram.

Function code	Name	Setting range
F4.09	V/F Slip compensation limit	0.0~200% 【0.0%】

The slip compensation function calculates the torque of motor according to the output current and compensates for output frequency. This function is used to improve speed accuracy when operating with a load. F4.09 sets the slip compensation limit as a percentage of motor rated slip; the slip compensation limit is calculated as the formula:

$$F4.09 = f_b - n * p / 60$$

0: Disabled

1: Enabled

While there is a light or empty load such as pumps or fans, it will reduce the inverter output voltage and save energy through detecting the load current.

Notes: This functions is good for fan and pump application

Function code	Name	Setting range
F4.11	Low-frequency threshold of restraining oscillation	0~10 【2】
F4.12	High-frequency	0~10 【0】

	y threshold of restraining oscillation	
F4.13	Boundary of restraining oscillation	0.00Hz~F0.03 【30.00Hz】

F4.11~F4.12 are only valid in the V/F control mode, When set F4.11 and F4.12 to be 0, the restraining oscillation is invalid. While set the values to be 1~3 will have the effect of restraining oscillation. When the running frequency is lower than F4.13, F4.11 is valid, when the running frequency higher than F4.13, F4.12 is valid.

F5 Group Input Terminals

There are 8 multi-function digital input terminals and 2 analog input terminals in M430 series inverters.

Function code	Name	Setting range
F5.00	HDI selection	0~1 【0】

0: High speed pulse input

1: ON-OFF input

Function code	Name	Setting range
F5.01	S1 terminal function	0~39 【1】
F5.02	S2 terminal function	0~39 【4】
F5.03	S3 terminal function	0~39 【7】
F5.04	S4 terminal function	0~39 【0】

Function code	Name	Setting range
F5.05	S5 terminal function	0~39 【0】
F5.06	S6 terminal function	0~39 【0】
F5.07	S7 terminal function	0~39 【0】
F5.08	HDI terminal function	0~39 【0】
0	Invalid	Please set unused terminals to be invalid to avoid malfunction

1	Forward	Please refer to description of F5.10.
2	Reverse	
3	3-wire control	Please refer to description of F5.10.
4	Jog forward	Please refer to description of F8.06~F8.08.
5	Jog reverse	
6	Coast to stop	The inverter blocks the output immediately. The motor coasts to stop by its mechanical inertia.
7	Reset fault	Resets faults that have occurred. It has the same function as STOP/RST.
8	Pause running	When this terminal takes effect, inverter decelerates to stop and save current status, such as PLC, traverse frequency and PID. When this terminal takes no effect, inverter restores the status.
9	External input fault	Stop the inverter and output an alarm when a fault occurs in a peripheral device.

10: Up command (UP)

11: DOWN command (DOWN)

12: Clear UP/DOWN

The reference frequency of inverter can be adjusted by UP command and DOWN command.

These three functions are used to modify the reference frequency through external terminals. UP is the increasing command, DOWN is the decreasing command, and the Clear UP/DOWN is used to restore to the reference frequency given by the frequency command channel.

13: Switch between A and B

14: A setting and Switch between A and B

15: B setting and Switch between A and B

16、17、18、19: Multi step speed1~4

16 steps speed control can be realized by the combination of these four terminals. For details, please refer to: Multi-step speed reference terminal status and according step value table

Notes: Multi speed terminal 1 is low position, 4 is high position.

Multi 4	Multi3	Multi 2	Multi1
BIT3	BIT2	BIT1	BIT0

20: Multi speed stop

Keep current step unchanged no matter what

the input

21, 22: ACC/DEC time select terminal 1, 2 groups of ACC/DEC time can be selected by the combination of these two terminals:

Terminal 2	Terminal 1	ACC/DEC time select	parameter
OFF	OFF	ACC/DEC time 0	F0.11 F0.12
OFF	ON	ACC/DEC time 1	F8.00 F8.01
ON	OFF	ACC/DEC time 2	F8.02 F8.03
ON	ON	ACC/DEC time 3	F8.04 F8.05

23: Reset simple PLC when stop

When simple PLC stops, the status of PLC such as running step, running time and running frequency will be cleared when this terminal is enabled.

24: Pause simple PLC

Inverter runs at zero frequency and PLC

pauses the timing when this terminal is enabled. If this terminal is disabled, inverter will start and continue the PLC operation from the status before pause.

25: Pause PID

PID adjustment will be paused and inverter keeps output frequency unchanged.

26: Pause traverse operation

Inverter keeps output frequency unchanged. If this terminal is disabled, inverter will continue traverse operation with current frequency.

27: Reset traverse operation

Reference frequency of inverter will be forced as center frequency of traverse operation.

28: Reset counter

Clear the value of counter.

29: Forbid torque control mode

Torque control is forbidden and switch inverter to run in speed control mode.

30: Forbid the function of ACC/DEC

ACC/DEC is invalid and maintains output frequency if it is enabled.

31: Counter input

The pulse input terminal of internal counter.

Maximum pulse frequency: 200Hz.

32: UP/DOWN invalid temporarily

UP/DOWN setting is invalid but will not be cleared. When this terminal is disabled, UP/DOWN value before will be valid again.

33-39: Reserved

Function code	Name	Setting range
F5.09	ON-OFF filter times	0~10 【5】

This parameter is used to set filter strength of terminals (S1~S7, HDI). When interference is heavy, user should increase this value to prevent malfunction.

Function code	Name	Setting range
F5.10	Terminal control mode	0~3 【0】

This parameter defines four different control modes that control the inverter operation through external terminals.

0: 2-wire control mode 1: Integrate **REV/FWD** command with run direction.

K1	K2	Run command
OFF	OFF	Stop
ON	OFF	FWD
OFF	ON	REV
ON	ON	Maintenance

Figure 6.9 2-wire control mode 1.

1: 2-wire control mode 2: START/STOP command is determined by FWD terminal. Run direction is determined by REV terminal.

K1	K2	Run command
OFF	OFF	Stop
ON	OFF	FWD
OFF	ON	Stop
ON	ON	REV

Figure 6.10 2-wire control mode 2.

2: 1: Terminal SIn is the multifunctional input terminal, run command by FWD, direction control by REV. SIn always close input .

K	Run command
OFF	FWD
ON	REV

Figure 6.121 3-wire control mode 1.

K: FWD/REV key

SB1: Run button

SB2: Stop button

Sin set for 3 NO. function3-wires running

contry multi-functions input terminal .

3: 3-wire control mode 2

SB1: Forward run button

SB2: Stop button (NC)

SB3: Reverse run button

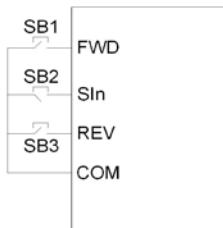

Figure 6-12 3-wire control mode 2.

SB1: FWD/REV key

SB2: Stop button

SB3: REV Running button

Note: When 2-wire control mode is active, the inverter will not run in following situation even

if FWD/REV terminal is enabled:

- **Coast to stop** (press **RUN** and **STOP/RST** at the same time).
- **Stop command from serial communication.**Some use function see **F7.04**

These parameters determine the relationship between analog input voltage and the corresponding setting value. When the analog input voltage exceeds the range between lower limit and upper limit, it will be regarded as the upper limit or lower limit.

The analog input AI1 can only provide voltage input, and the range is -10V~10V. For different applications, the corresponding value of 100.0% analog setting is different. For details, please refer to description of each application.

Note: AI1 lower limit must be less or equal to AI1 upper limit.

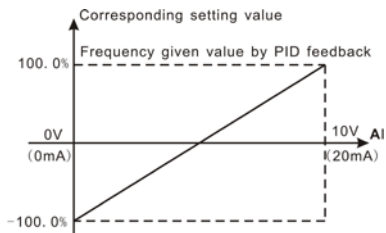

Figure 6-13 Relationship between AI and corresponding setting.

AI1 filter time constant is effective when there are sudden changes or noise in the analog input signal. Responsiveness decreases as the setting increases.

Function code	Name	Setting range
F5.17	AI2 lower limit	0.00~10.00V 【0.00V】
F5.18	AI2 lower limit corresponding setting	-100.0~100.0% 【0.0%】
F5.19	AI2 upper limit	0.00~10.00V 【10.00V】
F5.20	AI2 upper limit corresponding	-100.0~100.0% 【100.0%】

Function code	Name	Setting range
	setting	
F5.21	AI2 filter time constant	0.00~10.00s 【0.10s】

Analog value AI2 can set 0~10V/0~20mA input when AI2 select 0~20mA input 20mA as the voltage is 5V.

Function code	Name	Setting range
F5.22	HDI lower limit	0.00~50.00kHz 【0.00kHz】
F5.23	HDI lower limit corresponding setting	-100.0~100.0% 【0.0%】
F5.24	HDI upper limit	0.00~50.00kHz 【50.00kHz】
F5.25	HDI upper limit corresponding setting	-100.0~100.0% 【100.0%】
F5.26	HDI filter time constant	0.00~10.00s 【0.10s】

The description of F5.22~F5.26 is similar to A11.

F6 Group Output Terminals

There are 1 multi-function digital output terminal, 2 multi-function relay output terminals, 1 HDO terminal and 1 multi-function analog output terminal in M430 series inverters.

Function code	Name	Setting range
F6.00	HDO select	0~1 【0】

0: High-speed pulse output: The maximum pulse frequency is 50.0 kHz. Please refer to description of F6.06.

1: ON-OFF output: Please refer to description of F6.01.

Function code	Name	Setting range
F6.01	HDO ON-OFF output selection	0~20 【1】
F6.02	Relay 1 output selection	0~20 【4】

F6.03	Relay 2 output selection (4.0kW and above)	0~20 【0】
-------	--	-----------------

OC/Relay output functions are indicated in the following table:

0: No output.

1: Running, ON: Run command is ON or voltage is being output.

2: Run forward, ON: During forward run.

3: Run reverse, ON: During reverse run.

4: Fault output, ON: Inverter is in fault status.

5: FDT reached, Please refer to description of F8.21, F8.22.

6: Frequency reached, Please refer to description of F8.23.

7: Zero speed running, ON: The running frequency of inverter and setting frequency are zero.

8: Preset count value reached. Please refer to description of F8.18.

9: Specified count value reached, Please refer to description of F8.19.

10: overload pre-warming of inverter. Please refer to description of Fb.04~Fb.06

11: Simple PLC step completed

, After simple PLC completes one step, inverter will output ON signal for 500ms.

12: PLC cycle completed. After simple PLC completes one cycle, inverter will output ON signal for 500ms.

13: Running time reached, ON: The accumulated running time of inverter reaches the value of F8.20.

14: Upper frequency limit reached, ON: Running frequency reaches the value of F0.04.

15: Lower frequency limit reached, ON: Running frequency reaches the value of F0.05.

16: Ready, ON: Inverter is ready (no fault, power is ON).

17~20: Reserved

Function code	Name	Setting range
F6.04	AO1 function selection	0~10 【0】
F6.05	AO2 function	0~10 【0】

	selection	
F6.06	HDO function selection	0~10 【0】

Standard output the analog value is 0~20mA (or 0~10V), AO1 can select current/voltage by jumper J3, AO2 can select current/voltage by jumper J4. HDO input plause from 0kHz to 50.00kHz setting.

Setting Value	Function	Range
0	Running frequency	0~Maximum frequency
1	Reference frequency	0~Maximum frequency
2	Running speed	0~2* rated synchronous speed of motor
3	Output current	0~2* inverter rated current
4	Output voltage	0~1.5* inverter rated voltage
5	Output power	0~2* rated power

6	Setting torque	0~2*rated current of motor
7	Output torque	0~2*rated current of motor
8	AI1 voltage	0~10V
9	AI2 voltage/current	0~10V/0~20mA
10	HDI frequency	0.1~50.0kHz

Function code	Name	Setting range
F6.07	AO1 lower limit	0.0~100.0% 【0.0%】
F6.08	AO1 lower limit corresponding output	0.00~10.00V 【0.00V】
F6.09	AO1 upper limit	0.0~100.0% 【100.0%】
F6.10	AO1 upper limit corresponding output	0.00~10.00V 【10.00V】

These parameters determine the relationship between analog output voltage/current and the corresponding output value. When the analog output value exceeds the range between lower limit and upper limit, it will output the upper limit or lower limit.

When AO1 is current output, 1mA is corresponding to 0.5V.

For different applications, the corresponding value of 100.0% analog output is different. For details, please refer to description of each application.

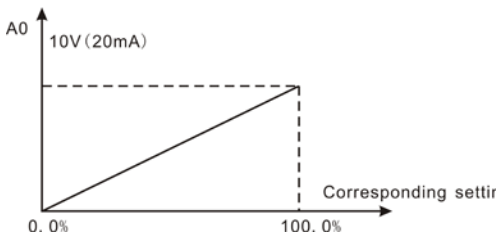

Figure 6.14 Relationship between AO and corresponding setting.

Function code	Name	Setting range
F6.11	AO2 lower limit	0.0~100.0% 【0.0%】
F6.12	AO2 lower limit corresponding output	0~10.00V 【0.00V】
F6.13	AO2 upper limit	0.0~100.0% 【100.0%】
F6.14	AO2 upper limit corresponding output	0.00~10.00V 【10.00V】
F6.15	HDO lower limit	0.0~100.0% 【0.0%】
F6.16	HDO lower limit corresponding output	0.00~50.00kHz 【0.00kHz】
F6.17	HDO upper limit	0.0~100.0% 【100.0%】
F6.18	HDO upper limit corresponding output	0.00~50.00kHz 【50.00kHz】

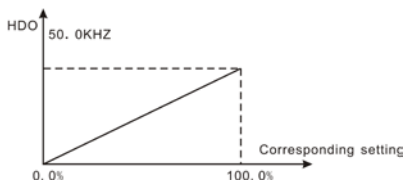

Figure 6.15 Relationship between HDO and corresponding setting.

F7 Group Display Interface

Function code	Name	Setting range
F7.00	User password	0~65535 【0】

The password protection function will be valid when F7.00 is set to be any nonzero data. When F7.00 is set to be 00000, user's password set before will be cleared and the password protection function will be disabled.

After the password has been set and becomes valid, the user can not access menu if the user's password is not correct. Only when a correct user's password is input, the user can see and modify the parameters. Please keep user's password in mind.

The password protection becomes valid in 1 minute after quitting from the function code editing state. Press **PRG/ESC** again to the function code editing state, "0.0.0.0.0" will be displayed. Unless using the correct password, the operators cannot enter it.

Function code	Name	Setting range
F7.01	Reserved	0~1 【0】
F7.02	Reserved	0~2 【0】
F7.03	QUICK/JOG function selection	0~4 【0】

QUICK/JOG is a multifunctional key, whose function can be defined by the value

0: Display status switching

1: Jog: Press **QUICK/JOG**, the inverter will jog.

2: FWD/REV switching: Press **QUICK/JOG**, the running direction of inverter will reverse. It is only valid if F0.03 is set to be 0.

3: Clear UP/DOWN setting: Press **QUICK/JOG**,

the UP/DOWN setting will be cleared.

4. Quick debugging mode

Function code	Name	Setting range
F7.04	STOP/RST function selection	0~3 【0】

0: Valid when keypad control 1: Valid when keypad or terminal control

2: Valid when keypad or communication control

3: Always valid

Note:

- The value of F7.04 only determines the STOP function of **STOP/RST**.
- The RESET function of **STOP/RST** is always valid.

Function code	Name	Setting range
F7.05	Keypad display selection	0~3 【0】

0: When external keypad exists, local keypad will be invalid.

1: Local and external keypad display

simultaneously, only the key of external keypad is valid.

2: Local and external keypad display

simultaneously, only the key of local keypad is valid.

3: Local and external keypad display

simultaneously, both keys of local and external keypad are valid.

Note: This function should be used cautiously, otherwise it may cause malfunction.

Function code	Name	Setting range
F7.06	Running status display selection 1	0~0xFFFF 【0x07FF】

When the M430 series frequency inverter running, parameter display effect by function code. If Bit is 1, the parameter will be displayed. Press **↵/SHIFT** to scroll through these parameters in right order. Press **DATA/ENT** + **QUICK/JOG** to scroll through these parameters in left order. The display content corresponding to each bit of

F7.06 is described in the following table:

	BIT15	BIT14	BIT13	BIT12	BIT11	BIT10
Step No. of PLC or multi-step	Count value	Torque setting value	Output terminal status	Input terminal status	PID feedback	
	BIT9	BIT8	BIT7	BIT6	BIT5	BIT4
PID preset	Output torque	Output power	Line speed	Rotation speed	Output current	
	BIT3	BIT2	BIT1	BIT0		
Output voltage	DC bus voltage	Reference frequency	Running frequency			

Input /output terminal condition display by into the system. S1 (HDO) as lowest position For example input position display 3, means S1 ,S2 always close, other terminal break, the detailed information please check F7.23 and F7.24

Function code	Name	Setting range
F7.07	Running	0~0xFFFF

	status display selection 2	【0x0000】
--	----------------------------	-----------------

The display content corresponding to each bit of

F7.8 is described in the following table:

BIT15	BIT14	BIT13	BIT12	BIT11	BIT10
Reserved	Reserved	Reserved	Reserved	Reserved	Reserved
BIT9	BIT8	BIT7	BIT6	BIT5	BIT4
Reserved	Reserved	Reserved	Reserved	Reserved	Inverter overload %

BIT3	BIT2	BIT1	BIT0
Motor overload %	HDI	AI2	AI1

Function code	Name	Setting range
F7.08	Stop status display selection	0~0xFFFF 【0x07FF】

F7.08 determines the display parameters in stop status. The setting method is similar with F7.06

Stop status display as follow:

BIT15	BIT14	BIT13	BIT12	BIT11	BIT10
Reserved	Reserved	Reserved	Reserved	Reserved	Torque set value
BIT9	BIT8	BIT7	BIT6	BIT5	BIT4
PLC	HDI	AI2	AI1	PID feedback	PID preset
BIT3	BIT2	BIT1	BIT0		
output terminal	Input terminal	DC BUS	Set frequency		

Function code	Name	Setting range
F7.09	Coefficient of rotation speed	0.1~999.9% 【100.0%】

This parameter is used to calibrate the bias between actual mechanical speed and rotation speed. The formula is as below:

$$\text{Actual mechanical speed} = 120 * \text{output frequency F7.09} / \text{Number of poles of motor.}$$

Function code	Name	Setting range
F7.10	Coefficient of line speed	0.1~999.9% 【1.0%】

This parameter is used to calculate the line speed based on actual mechanical speed. The formula is as below:

Line speed = actual mechanical speed *F7.10

Function code	Name	Setting range
F7.11	Rectify module temperature	0~100.0°C
F7.12	IGBT module temperature	0~100.0°C
F7.13	Software version	
F7.14	Inverter rated power	0~3000kW 【Depend on model】
F7.15	Inverter rated current	0.0~6000A 【Depend on model】
F7.16	Accumulated running time	0~65535h

Rectify module temperature: Indicates the temperature of rectify module. Overheat protection point of different model may be different.

IGBT module temperature: Indicates the temperature of IGBT module. Overheat protection point of different model may be different.

Software version: Indicates current software version of DSP. Accumulated running time: Displays accumulated running time of inverter.

Function code	Name	Setting range
F7.17	Third latest fault type	0~25
F7.18	Second latest fault type	0~25
F7.19	Latest fault type	0~25

These parameters record three recent fault types. 0 means there is no fault and 0~25 means there are 25 faults. For details, please refer to fault analysis.

Function code	Name	Setting range
F7.20	Output	

	frequency at current fault	
F7.21	Output current at current fault	
F7.22	DC bus voltage at current fault	
F7.23	Input terminal status at current fault	
F7.24	Output terminal status at current fault	

1 indicates corresponding input terminal is ON, while 0 indicates OFF. This value records output terminal status at current fault. This value is displayed as decimal. The meaning of each bit is as below:

BIT7	BIT6	BIT5	BIT4
HDI	S7	S6	S5
BIT3	BIT2	BIT1	BIT0
S4	S3	S2	S1

1 indicates corresponding input terminal is ON, while 0 indicates OFF. This value records output terminal status at current fault.

This value is displayed as decimal. The meaning of each bit is as below:

BIT3	BIT2	BIT1	BIT0
Reserved	RO2	RO1	HDO

1 indicates corresponding output terminal is ON, while 0 indicates OFF. Notice: This value is displayed as decimal.

F8Group Enhanced Function

Function code	Name	Setting range
F8.00	Acceleration time 1	0.1~3600.0s 【Depend on model】
F8.01	Deceleration time 1	0.1~3600.0s 【Depend on model】
F8.02	Acceleration time 2	0.1~3600.0s 【Depend on model】

F8.03	Deceleration time 2	0.1~3600.0s 【Depend on model】
F8.04	Acceleration time 3	0.1~3600.0s 【Depend on model】
F8.05	Deceleration time 3	0.1~3600.0s 【Depend on model】

ACC/DEC time can be selected among F0.11, F0.12 and the above three groups. Their meanings are the same. Please refer to the relative instructions of F0.11 and F0.12.

Select the ACC/DEC time 0~3 through the different combination of the multi-function digital terminals when the inverter runs.

Function code	Name	Setting range
F8.06	Jog reference	0.00~F0.03 【5.00Hz】
F8.07	Jog acceleration time	0.1~3600.0s 【Depend on model】

F8.08	Jog deceleration time	0.1~3600.0s 【Depend on model】
-------	-----------------------	----------------------------------

Function code	Name	Setting range
F8.09	Skip Frequency 1	0.00~F0.03 【0.00Hz】
F8.10	Skip Frequency 2	0.00~F0.03 【0.00Hz】
F8.11	Skip frequency bandwidth	0.00~F0.03 【0.00Hz】

By means of setting skip frequency, the inverter can keep away from the mechanical resonance with the load. F8.09 and F8.10 are centre value of frequency to be skipped.

Notice:

- If F8.11 is 0, the skip function is invalid.
- If both F8.09 and F8.10 are 0, the skip function is invalid no matter what F8.11 is.
- Operation is prohibited within the skip

frequency bandwidth, but changes during acceleration and deceleration are smooth without skip.

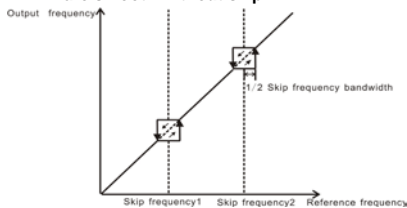

Figure6-16 Skip frequency diagram.

Function code	Name	Setting range
F8.12	Traverse amplitude	0.0~100.0% 【0.0%】
F8.13	Jitter frequency	0.0~50.0% 【0.0%】
F8.14	Rise time of traverse	0.1~3600.0s 【5.0s】
F8.15	Fall time of traverse	0.1~3600.0s 【5.0s】

Traverse function applies to the industries where need the traverse and convolution function such as textile and chemical fiber industries.

The traverse function means that the output frequency of the inverter is fluctuated with the set frequency as its center. The route of the running frequency is illustrated as below, of which the traverse is set by F08.12 and when F08.12 is set as 0, the traverse is 0 with no function.

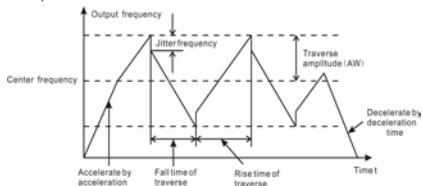

Figure 6.17 Traverse operation diagram.

Traverse range: The traverse running is limited by upper and low frequency.

The traverse range relative to the center frequency: $\text{traverse range AW} = \text{center frequency} \times \text{traverse range F08.12}$.

Sudden jumping frequency = traverse range $\text{AW} \times \text{sudden jumping frequency range F08.13}$.

When run at the traverse frequency, the value which is relative to the sudden jumping frequency.

The raising time of the traverse frequency: The

time from the lowest point to the highest one.

The declining time of the traverse frequency : The time from the highest point to the lowest one.

Function code	Name	Setting range
F8.16	Auto reset times	0~3 【0】
F8.17	Reset interval	0.1~100.0s 【1.0s】

The times of the fault reset: the inverter set the fault reset times by selecting this function. If the reset times exceed s this set value, the inverter will stop for the fault and wait to be repaired.

The interval time of the fault reset: The interval between the time when the fault occurs and the time when the reset action occurs

Function code	Name	Setting range
F8.18	Preset count value	F8.19~65535 【0】
F8.19	Specified count value	0~F8.18 【0】

The count pulse input channel can be S1~S4 ($\leq 200\text{Hz}$) and HDI.

If function of output terminal is set as preset count reached, when the count value reaches preset count value (F8.18), it will output an ON-OFF signal. Inverter will clear the counter and restart counting.

If function of output terminal is set as specified count reached, when the count value reaches specified count value (F8.19), it will output an ON-OFF signal until the count value reaches preset count value (F8.18). Inverter will clear the counter and restart counting.

Note:

- **Specified count value (F8.19) should not be greater than preset count value (F8.18).**
- **Output terminal can be RO1, RO2 or HDO.**

This function is shown as following figure.

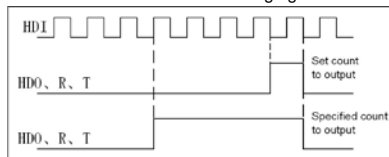

Figure 6.18 Timing chart for preset and specified count reached.

Function code	Name	Setting range
F8.20	Preset running time	0~65535h 【65535h】

Pre-set running time of the inverter.

When the accumulative running time achieves the set time, the multi-function digital output terminals will output the signal of "running time arrival".

Function code	Name	Setting range
F8.21	FDT level	0.00~F0.03 【50.00Hz】
F8.22	FDT lag	0.0~100.0 【5.0%】

When the output frequency reaches a certain preset frequency (FDT level), output terminal will output an ON-OFF signal until output frequency drops below a certain frequency of FDT level (FDT level - FDT lag), as shown in following figure.

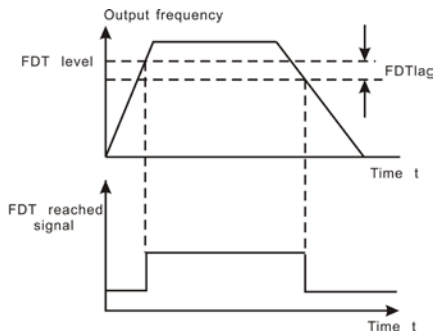

Figure 6-19 FDT level and lag diagram.

Function code	Name	Setting range
F8.23	Frequency arrive detecting range	0.0~100.0% 【0.0%】

When output frequency is within the detecting range of reference frequency, an ON-OFF signal will be output. The function can adjust the detecting range.

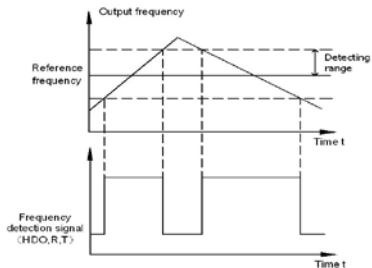

Figure 6.20 Frequency arriving detection diagram.

Function code	Name	Setting range
F8.24	Droop control	0.00~10.00Hz 【0.00Hz】

When several motors drive the same load, each motor's load is different because of the difference of motor's rated speed. The load of different motors can be balanced through droop control function which makes the speed droop along with load increase. When the motor outputs rated torque, actual frequency drop is equal to F8.24. User can adjust this parameter from small to big gradually during commissioning. The relation between load and output frequency is in the

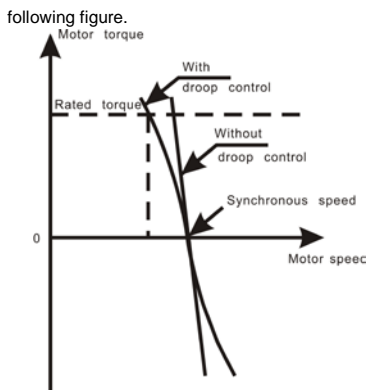

Figure 6.21 Droop control diagram.

Function code	Name	Setting range
F8.25	Brake threshold voltage	115.0~140.0% 【Depend on Model】

When the DC bus voltage is greater than the value of F8.25, the inverter will start dynamic braking.

Notice:

- **Factory setting is 120% if rated voltage of inverter is 220V.**
- **Factory setting is 130% if rated voltage**

of inverter is 380V.

- The value of F8.25 is corresponding to the DC bus voltage at rated input voltage.

Function code	Name	Setting range
F8.26	Cooling fan control	0~1 【0】

0: Auto stop mode: The fan keeps working when the inverter is running. When the inverter stops, whether the fan works or not depends on the module temperature of inverter.

1: The fan keeps working when powering on.

Function code	Name	Setting range
F8.27	Over modulation	0~1 【0】

0: the function is invalid 1: the function is valid

The function is applicable in the instance of low network voltage or heavy load for a long time, inverter raises the output voltage with rising utilization rate of bus voltage.

Function code	Name	Setting range
F8.28	PWM	0~2 【0】

0: PWM as 1, Noise in lower frequency is low, Noise in high frequency is high

1: PWM as 2, noise is so lower when motor working under this mode, but temperature rise is high, select the small KW frequency inverter use

2: PWM as 3, noise is so high when motor working under this mode, Be more effective to restrain the oscillation

F9 Group PID Control

PID control is a common used method in process control, such as flow, pressure and temperature control. The principle is firstly to detect the bias between preset value and feedback value, then calculate output frequency of inverter according to proportional gain, integral and differential time. Please refer to following figure.

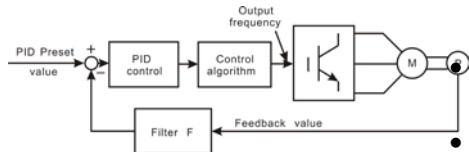

Figure 6-22 PID control diagram

Function code	Name	Setting range
F9.00	PID preset source selection	0~5 【0】

0: Keypad (F9.01)

1: AI1

2: AI2

3: HDI

4: Multi-step

5: Communication

When F0.07=6, this function is valid. The parameter determines the target given channel during the PID procures.

These parameters are used to select PID preset and feedback source.

Note:

- **Preset value and feedback value of PID**

are percentage value.

100% of preset value is corresponding to 100% of feedback value.

Preset source and feedback source must not be same, otherwise PID will be malfunction.

Function code	Name	Setting range
F9.01	Keypad PID preset	0.0~100.0% 【0.0%】

Set the parameter when F9.00=0.

The basic value of this parameter is the feedback value.

Function code	Name	Setting range
F9.02	PID feedback source selection	0~4 【0】

0: AI1

1: AI2

2: AI1+AI2

3: HDI

4: Communication

This parameter is used to select PID feedback source.

The given channel and the feedback channel can not coincide, otherwise, PID can not control effectively.

Function code	Name	Setting range
F9.03	PID output characteristic	0~1 【0】

0: Positive. When the feedback value is greater than the preset value, output frequency will be decreased, such as tension control in winding application.

1: Negative. When the feedback value is greater than the preset value, output frequency will be increased, such as tension control in unwinding application.

Function code	Name	Setting range
F9.04	(Kp)	0.00~100.00 【0.10】
F9.05	(Ti)	0.01~10.00s 【0.10s】

Function code	Name	Setting range
F9.06	Differential time (Td)	0.00~10.00s 【0.10s】

Optimize the responsiveness by adjusting these parameters while driving an actual load.

Adjusting PID control:

Use the following procedure to activate PID control and then adjust it while monitoring the response.

1. Enabled PID control (F0.07=6)
2. Increase the proportional gain (Kp) as far as possible without creating oscillation.
3. Reduce the integral time (Ti) as far as possible without creating oscillation.
4. Increase the differential time (Td) as far as possible without creating oscillation.

Making fine adjustments:

First set the individual PID control constants, and then make fine adjustments.

- Reducing overshooting

If overshooting occurs, shorten the differential

time and lengthen the integral time.

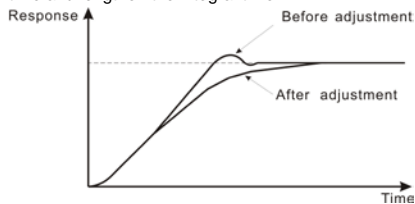

Reducing overshooting diagram.

- Rapidly stabilizing control status

To rapidly stabilize the control conditions even when overshooting occurs, shorten the integral time and lengthen the differential time.

- Reducing long-cycle oscillation

If oscillation occurs with a longer cycle than the integral time setting, it means that integral operation is strong. The oscillation will be reduced as the integral time is lengthened.

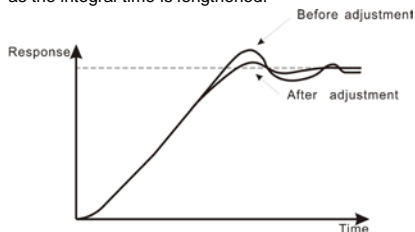

Reducing long-cycle oscillation diagram.

- Reducing short-cycle oscillation

If the oscillation cycle is short and oscillation occurs with a cycle approximately the same as the differential time setting, it means that the differential operation is strong. The oscillation will be reduced as the differential time is shortened.

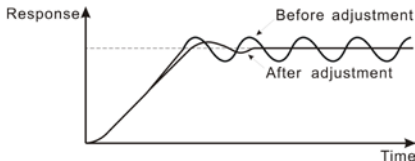

Reducing short-cycle oscillation diagram.

If oscillation cannot be reduced even by setting the differential time to 0, then either lower the proportional gain or raise the PID primary delay time constant.

Function code	Name	Setting range
F9.07	Sampling cycle (T)	0.01~100.00s 【0.10s】
F9.08	PID Bias limit	0.00~100.00% 【0.0%】

Sampling cycle T refers to the sampling cycle of feedback value. The PI regulator calculates once

in each sampling cycle. The bigger the sampling cycle is, the slower the response is.

Bias limit defines the maximum bias between the feedback and the preset. PID stops operation when the bias is within this range. Setting this parameter correctly is helpful to improve the system output accuracy and stability.

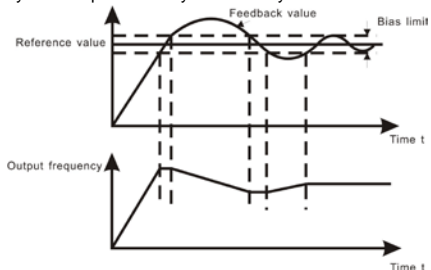

Figure 6-23 Relationship between bias limit and output frequency

Function code	Name	Setting range
F9.09	Feedback lost detecting value	0.0~100.0% 【0.0%】
F9.10	Feedback lost detecting time	0.0~3600.0s 【1.0s】

When feedback value is less than F9.09

continuously for the period determined by F9.10, the inverter will alarm feedback lost failure (PIDE).

Note: 100% of F9.09 is the same as 100% of F9.01.

FA Group Simple PLC and Multi-step Speed Control

Simple PLC function can enable the inverter to change its output frequency and directions automatically according to programmable controller PLC. For multi-step speed function, the output frequency can be changed only by multi-step terminals.

Note:

- Simple PLC has 16 steps which can be selected.
- If F0.07 is set to be 5, 16 steps are available for multi-step speed. Otherwise only 15 steps are available (step 1~15).

Function code	Name	Setting range
FA.00	Simple PLC mode	0~2 【0】

0: Stop after one cycle: Inverter stops automatically as soon as it completes one cycle, and it needs run command to start again.

1: Hold last frequency after one cycle: Inverter holds frequency and direction of last step after one cycle.

2: Circular run: Inverter continues to run cycle by cycle until receive a stop command.

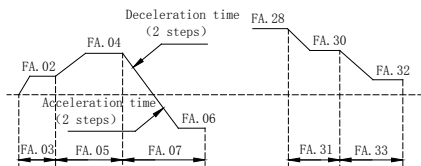

Figure 6.24 Simple PLC operation diagram.

Function code	Name	Setting range
FA.01	Simple PLC status saving after power off	0~1 【0】

0: Power loss without memory

1: Power loss memory

PLC record the running stage and frequency when power loss.

Function code	Name	Setting range
FA.02	Multi-step speed 0	-100.0~100.0% 【0.0%】
FA.03	0th running time	0.0~6553.5s 【0.0s】
FA.04	Multi-step speed 1	-100.0~100.0% 【0.0%】
FA.05	1th running time	0.0~6553.5s 【0.0s】
FA.06	Multi-step speed 2	-100.0~100.0% 【0.0%】
FA.07	2th running time	0.0~6553.5s 【0.0s】
FA.08	Multi-step speed 3	-100.0~100.0% 【0.0%】
FA.09	3th running time	0.0~6553.5s 【0.0s】
FA.10	Multi-step speed 4	-100.0~100.0% 【0.0%】
FA.11	4th running time	0.0~6553.5s 【0.0s】
FA.12	Multi-step speed 5	-100.0~100.0% 【0.0%】

Function code	Name	Setting range
FA.13	5th running time	0.0~6553.5s 【0.0s】
FA.14	Multi-step speed 6	-100.0~100.0% 【0.0%】
FA.15	6th running time	0.0~6553.5s 【0.0s】
FA.16	Multi-step speed 7	-100.0~100.0% 【0.0%】
FA.17	7th running time	0.0~6553.5s 【0.0s】
FA.18	Multi-step speed 8	-100.0~100.0% 【0.0%】
FA.19	8th running time	0.0~6553.5s 【0.0s】
FA.20	Multi-step speed 9	-100.0~100.0% 【0.0%】
FA.21	9th running time	0.0~6553.5s 【0.0s】
FA.22	Multi-step speed 10	-100.0~100.0% 【0.0%】

Function code	Name	Setting range
FA.23	10th Step running time	0.0~6553.5s 【0.0s】
FA.24	Multi-step speed 11	-100.0~100.0% 【0.0%】
FA.25	11th Step running time	0.0~6553.5s 【0.0s】
FA.26	Multi-step speed 12	-100.0~100.0% 【0.0%】
FA.27	12th Step running time	0.0~6553.5s 【0.0s】
FA.28	Multi-step speed 13	-100.0~100.0% 【0.0%】
FA.29	13th Step running time	0.0~6553.5s 【0.0s】
FA.30	Multi-step speed 14	-100.0~100.0% 【0.0%】
FA.31	14th Step running time	0.0~6553.5s 【0.0s】
FA.32	Multi-step speed 15	-100.0~100.0% 【0.0%】

Function code	Name	Setting range
FA.33	15th Step running time	0.0~6553.5s 【0.0s】

100.0% of the frequency setting corresponds to the Max. Frequency. (F0.04)

When selecting simple PLC running, set FA.02~FA.33 to define the running and direction of all stages.

Note: The symbol of multi-stage determines the running direction of simple PLC. The negative value means reverse rotation.

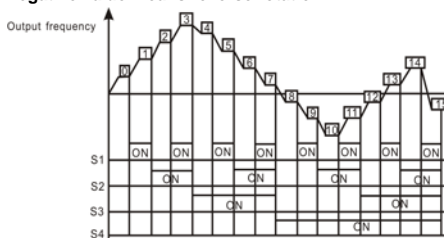

Figure 6.29 Multi-steps speed operation diagram.

Multi-stage speeds are in the range of -Fmax~Fmax and it can be set continuously.

M430 series inverters can set 16 stages speed, selected by the combination of multi-stage

terminals S1, S2, S3, S4, corresponding to the speed 0 to speed 15.

When S1=S2=S3=S4=OFF, the frequency input manner is selected via code F0.07 or F0.08. when all S1=S2=S3=S4 terminals aren't off, it runs at multi-stage which takes precedence of keypad, analog value, high-speed pulse, PLC, communication frequency input. Select at most 16 stages speed via the combination code of S1, S2, S3, and S4.

The start-up and stopping of multi-stage running is determined by function code F0.01, the relationship between S1, S2, S3, S4 terminals and multi-stage speed is as following:

S1	OFF	ON	OFF	ON	OFF	ON	OFF	ON
S2	OFF	OFF	ON	ON	OFF	OFF	ON	ON
S3	OFF	OFF	OFF	OFF	ON	ON	ON	ON
S4	OFF	OFF	OFF	OFF	OFF	OFF	OFF	OFF
Stage	0	1	2	3	4	5	6	7
S1	OFF	ON	OFF	ON	OFF	ON	OFF	ON
S2	OFF	OFF	ON	ON	OFF	OFF	ON	ON

S3	OFF	OFF	OFF	OFF	ON	ON	ON	ON
S4	ON	ON	ON	ON	ON	ON	ON	ON
stage	8	9	10	11	12	13	14	15

Function code	Name	Setting range
FA.34	PLC ACC/DEC time selection for step 0~7	0~0xFFFF 【0】

Binary Digit	step	ACC/DEC 0	ACC/DEC 1	ACC/DEC 2	ACC/DEC 3	
BIT1	BIT0	0	00	01	10	11
BIT3	BIT2	1	00	01	10	11
BIT5	BIT4	2	00	01	10	11
BIT7	BIT6	3	00	01	10	11
BIT9	BIT8	4	00	01	10	11
BIT11	BIT10	5	00	01	10	11

Binary Digit	step	ACC/DEC 0	ACC/DEC 1	ACC/DEC 2	ACC/DEC 3	
BIT3	BIT12	6	00	01	10	11
BIT15	BIT14	7	00	01	10	11

Function code	Name	Setting range
FA.35	PLC ACC/DEC time selection for step 8~15	0~0xFFFF 【0】

Binary Digit	step	ACC/DEC 0 0	ACC/DEC 1	ACC/DEC 2	ACC/DEC 3	
BIT1	BIT0	8	00	01	10	11
BIT3	BIT2	9	00	01	10	11
BIT5	BIT4	10	00	01	10	11

Binary Digit		step	ACC/DEC 0 0	ACC/DEC 1	ACC/DEC 2	ACC/DEC 3
BIT7	BIT6	11	00	01	10	11
BIT9	BIT8	12	00	01	10	11
BIT11	BIT10	13	00	01	10	11
BIT3	BIT12	14	00	01	10	11
BIT15	BIT14	15	00	01	10	11

After the users select the corresponding ACC/DEC time, the combining 16 binary bit will change into decimal bit, and then set the corresponding function codes.

Function code	Name	Setting range
FA.36	Simple PLC restart selection	0~1 【0】

0: Restart from step 0: If the inverter stops during running (due to stop command or fault), it will run from step 0 when it restarts.

1: Continue from interrupted step: If the inverter stops during running (due to stop command or

fault), it will record the running time of current step. When inverter restarts, it will resume from interrupted time automatically. For details, please refer to following figure.

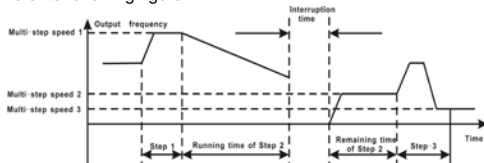

Figure 6.26 Simple PLC continues from interrupted step.

Function code	Name	Setting range
FA.37	Multi time unit select	0~1 【0】

0: Seconds

1: Minutes

This parameter determines the unit of x step running time

Fb Group Protection Function

Function code	Name	Setting range
---------------	------	---------------

Fb.00	Input phase-failure protection	0~1 【1】
Fb.01	Output phase-failure protection	0~1 【1】

0: Disable

1: Enable

Input phase loss protection: select whether to protect the input phase loss

Function code	Name	Setting range
Fb.02	Motor overload protection	0~2 【2】

1: For normal motor, the lower the speed is, the poorer the cooling effect is. Based on this reason, if output frequency is lower than 30Hz, inverter will reduce the motor overload protection threshold to prevent normal motor from overheat.

1: Common motor (with low speed compensation).

As the cooling effect of the common motor is weakened at low speed, the corresponding electronic heating protection is adjusted. The low speed compensation means decrease the motor overload protection threshold whose frequency is below 30Hz.

2: Variable frequency motor (without low speed compensation). As the cooling effect of variable frequency motor has nothing to do with running speed, it is not required to adjust the motor overload protection threshold.

Function code	Name	Setting range
Fb.03	Motor overload protection current	20.0~120.0% 【100.0%】

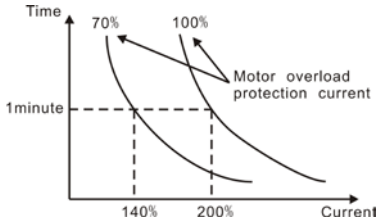

Figure 6.31 Motor overload protection curve.

The value can be determined by the following formula:

Motor overload protection current = (Maximum load current / inverter rated current) * 100%

Notice:

- This parameter is normally used when rated power of inverter is greater than rated power of motor.
- Motor overload protection time: 60s with 200% of rated current. For details, please refer to above figure.

Function code	Name	Setting range
Fb.04	Threshold of trip-free	70.0~110.0% 【80.0%】
Fb.05	Decrease rate of trip-free	0.00Hz~F0.03 【0.00Hz】

100% of Fb.04 corresponds to the standard bus voltage.

If Fb.05 is set to be 0, the trip-free function is invalid. Trip-free function enables the inverter to perform low-voltage compensation when DC bus voltage drops below Fb.04. The inverter can continue to run without tripping by reducing its output frequency and feedback energy via motor.

Note: If Fb.05 is too big, the feedback energy of motor will be too large and may cause over-voltage fault. If Fb.05 is too small, the feedback energy of motor will be too small to achieve voltage compensation effect. So please set Fb.05 according to load inertia and the actual load.

Function code	Name	Setting range
Fb.06	Over-voltage stall protection	0~1 【4】

0: Disabled

1: Enabled

Function code	Name	Setting range
Fb.07	Over-voltage stall protection point	110~150% 【120%】

During deceleration, the motor's decelerating rate may be lower than that of inverter's output frequency due to the load inertia. At this time, the motor will feed the energy back to the inverter, resulting in rise of DC bus voltage. If no measures taken, the inverter will trip due to over voltage.

During deceleration, the inverter detects DC bus voltage and compares it with over-voltage stall protection point. If DC bus voltage exceeds Fb.07, the inverter will stop reducing its output frequency. When DC bus voltage become lower than Fb.07, the deceleration continues, as shown in following figure.

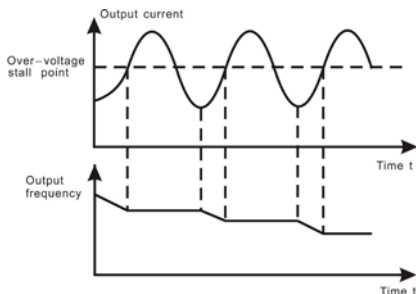

Figure 6.28 Over-voltage stall function.

Function code	Name	Setting range
Fb.08	Auto current limiting threshold	50.0~200.0% 【Depends on model】

Auto current limiting is used to limit the current of inverter smaller than the value determined by Fb.08 in real time. Fb.08 General purpose: 160%; Pump application: 120%.

Function code	Name	Setting range
Fb.09	Frequency decrease rate when current limiting	0.00~50.00Hz/s 【10.00Hz/s】

Fb.10	Auto current limiting selection	0~1 【0】
-------	---------------------------------	---------

0: Enabled

1: Disabled when constant speed

Therefore the inverter will not trip due to surge over-current. This function is especially useful for the applications with big load inertia or step change of load.

Fb.08 is a percentage of the inverter's rated current.

Fb.09 defines the decrease rate of output frequency when this function is active. If Fb.08 is too small, overload fault may occur. If it is too big, the frequency will change too sharply and therefore, the feedback energy of motor will be too large and may cause over-voltage fault. This function is always enabled during acceleration or deceleration. Whether the function is enabled in constant

Speed running is determined by Fb.10.

Note:

- **During auto current limiting process,**

the inverter's output frequency may change; therefore, it is recommended not to enable the function when inverter needs to output stable frequency

- **During auto current limiting process, if Fb.08 is too low, the overload capacity will be impacted.**

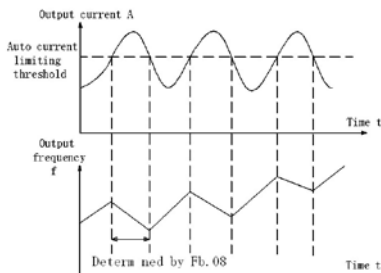

Figure 6.29

Current limiting protection function.

0: Enabled

1: Disabled when constant speed

Auto current limiting is used to limit the current of inverter smaller than the value determined by Fb.08 in real time. Therefore the inverter will not trip due to surge over-current. This function is

especially useful for the applications with big load inertia or step change of load.

Fb.08 is a percentage of the inverter's rated current. Fb.09 defines the decrease rate of output frequency when this function is active. If Fb.08 is too small, overload fault may occur. If it is too big, the frequency will change too sharply and therefore, the feedback energy of motor will be too large and may cause over-voltage fault. This function is always enabled during acceleration or deceleration. Whether the function is enabled in constant

Speed running is determined by Fb.10.

Note:

- **During auto current limiting process, the inverter's output frequency may change; therefore, it is recommended not to enable the function when inverter needs to output stable frequency**
- **During auto current limiting process, if Fb.08 is too low, the overload capacity will be impacted.**

Function code	Name	Setting range
Fb.11	Selection of over torque (OL3)	0~4 【1】

0: No detection

1: Valid detection of over torque during running, then continue running

2: Valid detection of over torque during running, then warning and stop

3: Valid detection of over torque during constant speed running, then continue running

4: Valid detection of over torque during constant speed running, then warning (OL3) and stop.

Function code	Name	Setting range
Fb.12	Detection level of over torque	10.0%~200.0% 【Depend on the model】

General purpose: 150%

Pump application: 120%

Function code	Name	Setting range
Fb.13	Detection time of over torque	0.1~60.0s 【0.1s】

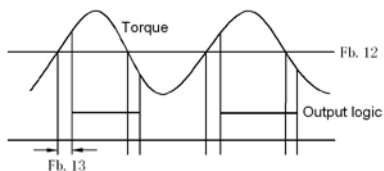

Figure 6.30 over torque control function.

If Fb.11 is set to be 1 or 3, and if the output torque of inverter reaches to Fb.12, and with delay of Fb.13, this will output the over torque. And the TRIP light will reflash. If F6.01 ~F6.03 are set to be 10, the output will be valid.

If Fb.11 is set to be 2 or 4, when over torque signal meets the output conditions, inverter performs warning signal OL3, and meanwhile stops the output.

FCGroupSerialCommunication

Function	Name	Setting range
----------	------	---------------

code		
FC.00	Local address	0~247 【1】

When the master is writing the frame, the communication address of the slave is set to 0, the address is the communication address. All slaves on the MODBUS fieldbus can receive the frame, but the slave doesn't answer.

The communication of the drive is unique in the communication net. This is the fundamental for the point to point communication between the upper monitor and the drive.

Note: The address of the slave cannot set to 0.

This parameter determines the slave address used for communication with master. The value "0" is the broadcast address.

Function code	Name	Setting range
FC.01	Baud rate selection	0~5 【3】

0: 1200bps

1: 2400bps

2: 4800bps

3: 9600bps

4: 19200bps

5: 38400bps

This parameter can set the data transmission rate during serial communication.

The baud rate between the upper monitor and the inverter must be the same. Otherwise, the communication is not applied. The bigger the baud rate, the quicker the communication speed.

Function code	Name	Setting range
FC.02	Data format	0~5 【0】

0: RTU, 1 start bit, 8 data bits, no parity check, 1 stop bit.

1: RTU, 1 start bit, 8 data bits, even parity check, 1 stop bit.

2: RTU, 1 start bit, 8 data bits, odd parity check, 1 stop bit.

3: RTU, 1 start bit, 8 data bits, no parity check, 2 stop bits.

4: RTU, 1 start bit, 8 data bits, even parity check, 2 stop bits.

5: RTU, 1 start bit, 8 data bits, odd parity check, 2

stop bits.

This parameter defines the data format used in serial communication protocol.

Function code	Name	Setting range
FC.03	Communication delay time	0~200ms 【5ms】

This parameter means the interval time when the drive receive the data and sent it to the upper monitor. If the answer delay is shorter than the system processing time, then the answer delay time is the system processing time, if the answer delay is longer than the system processing time, then after the system deal with the data, waits until achieving the answer delay time to send the data to the upper monitor.

Function code	Name	Setting range
FC.04	Communication timeout delay	0.0~100.0s 【0.0s】

When the function code is set as 0.0, the

communication overtime parameter is invalid.

When the function code is set to a valid value, if the interval time between two communications exceeds the communication overtime, the system will report "communication faults" (CE).

Generally, set it as invalid; set the parameter in the continuous communication to monitor the communication state.

Function code	Name	Setting range
FC.05	Communication error action	0~3 【1】

0: When communication error occurs, inverter will alarm (CE) and coast to stop.

1: When communication error occurs, inverter will omit the error and continue to run.

2: When communication error occurs, if F0.01=2, inverter will not alarm but stop according to stop mode determined by F1.06. Otherwise it will omit the error.

3: When communication error occurs, inverter will not alarm but stop according to stop mode

determined by F1.06.

Function code	Name	Setting range
FC.06	Response action	00~11 【00】

Unit's place of LED

0: Response to writing

1: No response to writing

Ten's place of LED

0: Reference not saved when power off

1: Reference saved when power off

Fd Group Supplementary

Function

Function code	Name	Setting range
Fd.00~ Fd.09	Reserved	

FE Group Factory Setting

This group is the factory-set parameter group. It is prohibited for user to modify.

7. COMMUNICATION PROTOCOL

7.1 Interfaces

RS485: asynchronous, half-duplex.

Default: 8-E-1, 19200bps. See Group PC parameter settings.

7.2 Communication Modes

7.2.1 The protocol is Modbus protocol. Besides the common register Read/Write operation, it is supplemented with commands of parameters management.

7.2.2 The drive is a slave in the network. It communicates in 'point to point' master-slave mode. It will not respond to the command sent by the master via broadcast address.

7.2.3 In the case of multi-drive communication or long-distance transmission, connecting a 100~120Ω resistor in parallel with the master signal line will help to enhance the immunity to interference.

7.3 Protocol Format

Modbus protocol supports both RTU. The frame format is illustrated as follows:

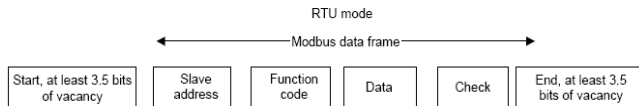

Modbus adopts "Big Endian" representation for data frame. This means that when a numerical quantity larger than a byte is transmitted, the most significant byte is sent first.

RTU mode

In RTU mode, the Modbus minimum idle time between frames should be no less than 3.5 bytes. The checksum adopts CRC-16 method. All data except checksum itself sent will be counted into the calculation. Please refer to section: CRC Check for more information. Note that at least 3.5 bytes of Modbus idle time should be kept and the start and end idle time need not be summed up to it.

The table below shows the data frame of reading parameter 002 from slave node address 1.

Node addr.	Command	Data addr.		Read No.		CRC	
0x01	0x03	0x00	0x02	0x00	0x01	0x25	0xCA

The table below shows the reply frame from slave node address 1

Node addr.	Command	Bytes No.	Data		CRC	
0x01	0x03	0x02	0x00	0x00	0xB8	0x44

7.4 Protocol function

Different respond delay can be set through drive's parameters to adapt to different needs. For RTU mode, the respond delay should be no less than 3.5 bytes interval.

The main function of Modbus is to read and write parameters. The Modbus protocol supports the following commands:

0x03	Read inverter's function parameter and status parameters
0x06	Write single function parameter or command parameter to inverter

All drive's function parameters, control and status parameters are mapped to Modbus R/W data address.

The data address of control and status parameters please refer to the following table.

Parameter Description	Address	Meaning of value	R/W Feature
Control command	1000H	0001H: Forward	W/R
		0002H: Reverse	
		0003H: JOG forward	
		0004H: JOG reverse	
		0005H: Stop	
		0006H: Coast to stop	
		0007H: Reset fault	
		0008H: JOG stop	
Inverter status	1001H	0001H: Forward running	R
		0002H: Reverse running	
		0003H: Standby	
		0004H: Fault	
		0005H: Status of inverter POFF	
Communication setting	2000H	<p>Communication Setting Range (-10000~10000)</p> <p>Note: the communication setting is the percentage of the relative value (-100.00%~100.00%). If it is set as frequency source, the value is the percentage of the maximum frequency. If it</p>	W/R

Parameter Description	Address	Meaning of value	R/W Feature
		is set as PID (preset value or feedback value), the value is the percentage of the PID.	
	2001H	PID setting. Range: 0~1000, 1000 means100.0%	W/R
	2002H	PID feedback. Range: 0~1000, 1000 means100.0%	W/R
	2003H	Setting value of torque Range: -1000~1000, 1000 means100.0%	W/R
	2004H	Setting value of upper limit frequency (0~Fmax)	W/R
Status parameters	3000H	Output frequency	R
	3001H	Reference frequency	R
	3002H	DC Bus voltage	R
	3003H	Output voltage	R
	3004H	Output current	R
	3005H	Rotation speed	R
	3006H	Output power	R
	3007H	Output torque	R
	3008H	PID preset value	R

Parameter Description	Address	Meaning of value	R/W Feature
	3009H	PID feedback value	R
	300AH	Input terminal status	R
	300BH	Output terminal status.	R
	300CH	Input of AI1	R
	300DH	Input of AI2	R
	300EH	Reserved	R
	300FH	Reserved	R
	3010H	HDI frequency	R
	3011H	Reserved	R
	3012H	Step No. of PLC or multi-step	R
	3013H	Reserved	R
	3014H	External counter input	R
	3015H	Torque setting	R

Parameter Description	Address	Meaning of value	R/W Feature
Inverter fault info address	5000H	0X00H: No fault 0X01H: SC1 0X02H: SC2 0X03H: SC3 0X04H: OC1 0X05H: OC2 0X06H: OC3 0X07H: OV1 0X08H: OV2 0X09H: OV3 0x0A: UV 0x0B: OL1 0x0C:OL2 0x0D: IPI 0x0E: SPO 0x0F: OH1 0x10: OH2 0x11: EF 0x12: CE 0x13: ItE	R

Parameter Description	Address	Meaning of value	R/W Feature
Inverter fault info address	5000H	0x14: tE 0x15: EEP 0x16:PIDE 0x17: bE 0x18: END 0x19: OL3	R

The above shows the format of the frame. Now we will introduce the Modbus command and data structure in details, which is called protocol data unit for simplicity. Also MSB stands for the most significant byte and LSB stands for the least significant byte for the same reason. The description below is data format in RTU mode.

Protocol data unit format of reading parameters:

Request format:

Protocol data unit	Data length(bytes)	Range
Command	1	0x03
Data Address	2	0~0xFFFF
Read number	2	0x0001~0x0010

Reply format (success):

Protocol data unit	Data length(bytes)	Range
Command	1	0x03

Returned byte number	2	2* Read number
Content	2* Read number	

If the operation fails, the inverter will reply a message formed by failure command and error code. The failure command is (Command+0x80). The error code indicates the reason of the error; see the table below.

Value	Name	Mean
01H	Illegal command	The command from master can not be executed. The reason maybe: 1 This command is only for new version and this version can not realize. 2 Slave is in fault status and can not execute it.
02H	Illegal data address.	Some of the operation addresses are invalid or not allowed to access.
03H	Illegal value	When there are invalid data in the message framed received by slave. Note: This error code does not indicate the data value to write exceed the range, but indicate the message frame is a illegal frame.
06H	Slave busy	Inverter is busy(EEPROM is storing)
10H	Password error	The password written to the password check address is not same as the password set by F7.00.
11H	Check error	The CRC (RTU mode) check not passed.
12H	Written not allowed.	It only happen in write command, the reason maybe: 1 The data to write exceed the range of according parameter 2 The parameter should not be modified now. 3 The terminal has already been used.

Value	Name	Mean
13H	System locked	When password protection take effect and user does not unlock it, write/read the function parameter will return this error.

Protocol data unit format of writing single parameter:

Request format:

Protocol data unit	Data length(bytes)	Range
Command	1	0x06
Data Address	2	0~0xFFFF
Write Content	2	0~0xFFFF

Reply format (success):

Protocol data unit	Data length(bytes)	Range
Command	1	0x06
Data Address	2	0~0xFFFF
Write Content	2	0~0xFFFF

If the operation fails, the inverter will reply a message formed by failure command and error code. The failure command is (Command+0x80). The error code indicates the reason of the error; see table 1.

7.5 Note:

9.5.1 Between frames, the span should not less than 3.5 bytes interval, otherwise, the message will be discarded.

7.5.2 Be cautious to modify the parameters of PC group through communication, otherwise may cause the communication interrupted.

7.5.3 In the same frame, if the span between two .near bytes more than 1.5 bytes interval, the behind bytes will be assumed as the start of next message so that communication will failure.

7.6 CRC Check

For higher speed, CRC-16 uses tables. The following are C language source code for CRC-16.

```
unsigned int crc_cal_value(unsigned char *data_value,unsigned char data_length)
{
int i;
unsigned int crc_value=0xffff;
while(data_length--)
{
crc_value^=*data_value++;
for(i=0;i<8;i++)
{
if(crc_value&0x0001)crc_value=(crc_value>>1)^0xa001;
else crc_value=crc_value>>1;
}
}
return(crc_value);
}
```

7.7 Example

RTU mode, read 2 data from 0004H

The request command is:

Advanced Systems Baltic OÜ —M430 series products

START	T1-T2-T3-T4 (transmission time of 3.5 bytes)
Node address	01H
Command	03H
High byte of start address	00H
Low byte of start address	04H
High byte of data number	00H
Low byte of data number	02H
Low byte of CRC	85H
High byte of CRC	CAH
END	T1-T2-T3-T4 (transmission time of 3.5 bytes)

The reply is :

START	T1-T2-T3-T4 (transmission time of 3.5 bytes)
Node address	01H
Command	03H
Returned byte number	04H
Higher byte of 0004H	00H
Low byte of 0004H	00H
High byte of 0005H	00H
Low byte of 0005H	00H
Low byte of CRC	43H
High byte of CRC	07H
END	T1-T2-T3-T4 (transmission time of 3.5 bytes)

RTU mode, write 5000(1388H) into address 0004H, slave node address 03

The request command is:

START	T1-T2-T3-T4 (transmission time of 3.5 bytes)
Node address	03H
Command	06H
High byte of data address	00H
Low byte of data address	04H
High byte of write content	13H
Low byte of write content	88H
Low byte of CRC	C4H
High byte of CRC	BFH
END	T1-T2-T3-T4 (transmission time of 3.5 bytes)

The reply command is:

START	T1-T2-T3-T4 (transmission time of 3.5 bytes)
Node address	03H
Command	06H
High byte of data address	00H
Low byte of data address	04H
High byte of write content	13H
Low byte of write content	88H
Low byte of CRC	C4H
High byte of CRC	BFH
END	T1-T2-T3-T4 (transmission time of 3.5 bytes)

8. TROUBLE SHOOTING

8.1 Fault and Trouble shooting

Fault Code	Fault Type	Reason	Solution
SC1	IGBT Ph-U fault	1. Acc time is too short.	1. Increase Acc time. 2. Ask for support. 3. Inspect external equipment and eliminate interference.
SC2	IGBT Ph-V fault	2. IGBT module fault.	
SC3	IGBT Ph-W fault	3. Malfunction caused by interference.	
		4. Grounding is not properly.	
OC1	Over-current when acceleration	1. Acc time is too short. 2. The voltage of the grid is too low. 3. The power of the inverter is too low.	1. Increase Acc time. 2. Check the input power 3. Select bigger capacity inverter.
OC2	Over-current when deceleration	1. Dec time is too short. 2. The torque of the load inertia is big. 3. The power of the inverter is too low.	1. Increase Dec time. 2. Install a proper energy consumption braking components 3. Select bigger capacity inverter.
OC3	Over-current when constant speed running	1 The load transients or is abnormal. 2. The voltage of the grid is	1. Check the load or reduce the transient of the load 2. Check the input power supply

Fault Code	Fault Type	Reason	Solution
		too low. 3. The power of the inverter is too low.	3. Select bigger capacity inverter.
OV1	Over-voltage when acceleration	1. The input voltage is abnormal 2. Restart the running motor after sudden power loss.	1 Check the input power 2.Avoid restart-up after stopping
OV2	Over-voltage when deceleration	1. Dec time is too short. 2.The inertia of the load is big. 3.The input voltage is abnormal	1.Increase the Dec time 2. Increase the energy-consuming components 3. Check the input power
OV3	Over-voltage when constant speed running	1. The input voltage changes abnormally. 2. The inertia of the load is big.	1. Install the input reactor 2.Add proper energy-consuming components
UV	DC bus Under-voltage	1. The voltage of the grid is low	1.Check the input power supply of the grid
OL1	Motor overload	1. The voltage of the power supply is too low. 2. The motor setting rated	1. Check the power of the supply line 2. Reset the rated current of the

Fault Code	Fault Type	Reason	Solution
		current is incorrect. 3. The motor stall or load transients is too strong. 4.The power of the motor is too big.	motor 3. Check the load and adjust the torque lift 4. Select a proper motor.
OL2	Inverter overload	1. The acceleration is too fast 2. Reset the rotating motor 3. The voltage of the power supply is too low. 4. The load is too heavy.	1. Increase the ACC time 2. Avoid the restarting after stopping. 3. Check the power of the supply line 4. Select an inverter with bigger power
IPL	Input phase loss	Phase loss or fluctuation of input R,S,T	1. Check input power 2. Check installation distribution
SPO	Output phase loss	U, V, W phase loss input(or serious asymmetrical three phase of the load)	1. Check the output distribution 2. Check the motor and cable

Fault Code	Fault Type	Reason	Solution
OH1	Rectify IGBT overheat	1.Sudden over current of the inverter 2.There is direct or indirect short circuit between output 3 phase	1. Refer to the over current solution
OH2	Inverter IGBT overheat	3.Air duct jam or fan damage 4.Ambient temperature is too high. 5.The wiring of the control panel or plug-ins are loose 6.The assistant power supply is damaged and the drive voltage is under voltage 7.The bridge arm of the power module is switched on 8.The control panel is abnormal	2. Redistribute 3. Dredge the wind channel or change the fan 4. Low the ambient temperature 5. Check and reconnect 6. Ask for service 7. Ask for service 8. Ask for service
EF	External fault	S1: External fault input terminal take effect.	1. Check the external device input
CE	Communication	1. The baud rate setting is	1. Set proper baud rate

Fault Code	Fault Type	Reason	Solution
	fault	incorrect. 2.Communication fault 3.The communication is off for a long time.	2. Press STOP/RST to reset and ask for help 3. Check the communication connection distribution
ItE	Current detection fault	1. The connection of the control board is not good Assistant power is bad 2. Assistant power is damaged 3. Hoare components is broken 4. The modifying circuit is abnormal.	1. Check and reconnect 2. Ask for service 3. Ask for service 4. Ask for service
tE	auto tuning fault	1. The motor capacity does not comply with the inverter capability 2. The rated parameter of the motor does not set correctly. 3. The offset between the parameters from auto tune and the standard parameter is huge 4. auto tune overtime	1.Change the inverter model 2.Set the rating parameters according to the nameplate of the motor 3.Empty the motor and identify again 4.Check the motor wiring and set the parameters

Fault Code	Fault Type	Reason	Solution
EEP	EEPROM fault	1. Error of controlling the write and read of the parameters 2. Damage to EEPROM	1. Press STOP/RST to reset 2. Ask for service
PIDE	PID feedback fault	1. PID feedback offline 2. PID feedback source disappear	1. Check the PID feedback signal wires 2. Check PID feedback source
bE	Braking unit fault	1. Braking circuit fault or damage to the braking pipes 2. The external braking resistor is a little low	1. Check the braking unit and change new braking pipes 2. Increase the braking resistor
END	Time reach of factory setting	1. Trial time arrival	1. Ask for service
OL3	over torque	1. The acceleration is too fast 2. Reset the rotating motor 3. The voltage of the power supply is too low. 4. The load is too heavy.	1. Increase the ACC time 2. Avoid the restarting after stopping. 3. Check the power of the supply line 4. Select an inverter with bigger power 5. Adjust Fb.11 to a proper value

8.2 Common Faults and Solutions

Inverter may have following faults or malfunctions during operation, please refer to the following solutions.

No display after power on:

- Inspect whether the voltage of power supply is the same as the inverter rated voltage or not with multi-meter. If the power supply has problem, inspect and solve it.
- Inspect whether the three-phase rectify bridge is in good condition or not. If the rectification bridge is burst out, ask for support.

Power supply air switch trips off when power on:

- Inspect whether the input power supply is grounded or short circuit. Please solve the problem.
- Inspect whether the rectify bridge has been burnt or not. If it is damaged, ask for support.

Motor doesn't move after inverter running:

- Inspect if there is balanced three-phase output among U, V, and W. If yes, then motor could be damaged, or mechanically locked. Please solve it.
- Ask for help if the output is unbalanced,
- Ask for help if there is no output voltage.

Inverter displays normally when power on, but switch at the input side trips when running:

- Inspect whether the output side of inverter is short circuit. If yes, ask for support.
- Inspect whether ground fault exists. If yes, solve it.
- If trip happens occasionally and the distance between motor and inverter is too far, it is recommended to install output AC reactor.

9. MAINTENANCE

WARNING

- Maintenance must be performed according to designated maintenance methods.
- Maintenance, inspection and replacement of parts must be performed only by certified person.
- After turning off the main circuit power supply, wait for 10 minutes before maintenance or inspection.
- DO NOT directly touch components or devices of PCB board. Otherwise inverter can be damaged by electrostatic.
- After maintenance, all screws must be tightened.

9.1 Daily Maintenance

In order to prevent the fault of inverter to make it operate smoothly in high-performance for a long time, user must inspect the inverter periodically (within half year). The following table indicates the inspection content.

Checking item	Content
Temperature/Humidity	Ensure the temperature is among 0 ~ 40 °C and the humidity is among 20~90%

Oil fog and dust	Ensure that there is no oil fog, dust and condensation in the inverter.
The inverter	Ensure there is no abnormal heating, and abnormal vibration to the inverter.
The fan	Ensure the fan rotates normally and there is no foreign objection in the inverter.
Input power supply	Ensure the voltage and frequency of the power supply is in the allowed range.
The motor	Ensure there is no abnormal vibration, heating noise and phase loss.

9.2 Periodic Maintenance

Customer should check the inverter every 6 months according to the actual environment.

Checking item	Content	Method
Screws of the external terminals	Check if the screw is loose or not.	Tighten up
PCB board	Dust and dirtiness	Clear the sundries with dry compressed air.
The fan	Check if the accumulative time of abnormal noise and vibration exceeds 20,000 hours.	<ol style="list-style-type: none"> 1. clear the sundries 2. change the fan
Electrolytic capacitance	Check if the color has changed and if it smelly	Change the electrolytic capacitance.
Heat sink	Dust and dirtiness	Clear the sundries with dry compressed air.
Power components	Dust and dirtiness	Clear the sundries with dry compressed air.

9.3 Replacement of wearing parts

Fans and electrolytic capacitors are wearing parts; please make periodic replacement to ensure long term, safety and failure-free operation. The replacement periods are as follows:

- ◆ Fan: Must be replaced when using up to 20,000 hours;
- ◆ Electrolytic Capacitor: Must be replaced when using up to 30,000–40, 000 hours.

9.4 Guarantee

There is a 12 months Warranty Period for your M430series inverter started from the date of purchase.

10. Specifications of Breaker, Cable, Contactor and Reactor

10.1 Brake Resistor

Type	Specification		Brake torque%	Motor General Purpose	Motor Pump application
	W	Ω			
ADV 0.75 M430-M	80	750	125	0.75	
ADV 1.50 M430-M	260	400	125	1.5	
ADV 2.20 M430-M	260	250	125	2.2	
ADV 5.50 M430-M	390	150	125	4	5.5
ADV 7.50 M430-M	500	100	125	5.5	7.5
ADV 11.0 M430-M	1000	75	125	7.5	11

ADV 15.0 M430-M	1000	50	125	11	15
ADV 18.5 M430-M	1500	40	125	15	18.5
ADV 22.0 M430-M	4800	32	125	18.5	22
ADV 30.0 M430-M	4800	27.2	125	22	30
ADV 37.0 M430-M	6000	20	125	30	37
ADV 45.0 M430-M	9600	16	125	37	45
ADV 55.0 M430-M	9600	14	125	45	55
ADV 75.0 M430-M	12000	10	125	55	75

NOTICE:

- 1、Select the resistance value and frequency from our company.
- 2、We don't bear any responsibility of inverter damage if braking resistance and chip used is not from our company.
- 3、Please check the safety and inflammable environment when install braking resistance.
- 4、If you want to change the resistance value and power,do contact your supplier.
- 5、You should order braking resistance and chip with your local supplier.

10.2 Specifications of breaker, cable, contactor and reactor

Type	Breaker(A)	cable	Contactor A (380V or 220V)
ADV 0.75 M430-M	10	2.5	10
ADV 1.50 M430-M	10	2.5	10
ADV 2.20 M430-M	16	2.5	10
ADV 5.50 M430-M	25	4	16

ADV 7.50 M430-M	25	4	16
ADV 11.0 M430-M	40	6	25
ADV 15.0 M430-M	63	6	32
ADV 18.5 M430-M	63	6	50
ADV 22.0 M430-M	100	10	63
ADV 30.0 M430-M	100	16	80
ADV 37.0 M430-M	125	25	95
ADV 45.0 M430-M	160	25	120
ADV 55.0 M430-M	200	35	135
ADV 75.0 M430-M	200	35	170

10.3 Specifications of input/output AC reactor and DC reactor

Type	Input AC reactor		Output AC reactor		DC reactor	
	Current (A)	Inductance (mH)	current (A)	Inductance (uH)	Current (A)	Inductance (mH)
ADV 0.75 M430-M ADV 1.50 M430-M	5	3.8	5	3.8	6	11
ADV 2.20 M430-M	7	2.5	7	1	6	11
ADV 5.50 M430-M	10	1.5	10	0.6	12	6.3
ADV 7.50 M430-M	15	1.0	15	0.25	23	3.6

ADV 11.0 M430-M	20	0.75	20	0.75	23	3.6
ADV 15.0 M430-M	30	0.60	30	0.087	33	2
ADV 18.5 M430-M	40	0.42	40	0.066	33	2
ADV 22.0 M430-M	50	0.35	50	0.052	40	1.3
ADV 30.0 M430-M	60	0.28	60	0.045	50	1.08
ADV 37.0 M430-M	80	0.19	80	0.032	65	0.80
ADV 45.0 M430-M	90	0.16	90	0.030	78	0.70
ADV 55.0 M430-M	120	0.13	120	0.023	95	0.54
ADV 75.0 M430-M	150	0.10	150	0.019	115	0.45

11. LIST OF FUNCTION PARAMETERS

The function parameters of M430 series inverters have been divided into 16 groups (F0-FE) according to the function. Each function group contains certain function codes applying 3-class menus. For example, "F8.08" means the eighth function code in the F8 group function, FE group is factory reserved, and users are forbidden to access these parameters.

For the convenience of function codes setting, the function group number corresponds to the first class menu, the function code corresponds to the second class menu and the function code corresponds to the third class menu.

1. Below is the instruction of the function lists:

The first line "Function code": codes of function parameter group and parameters;

The second line "Name": full name of function parameters;

The third line "Detailed illustration of parameters": Detailed illustration of the function parameters

The fourth line "setting range": the effective setting range of the function parameters which will displayed on the LCD:

The fifth line "Default value": the original factory set value of the function parameter;

The sixth line "Modify": the modifying character of function codes (the parameters can be modified or not and the modifying conditions), below is the instruction:

"o": means the set value of the parameter can be modified on stop and running state;

"

⊙": means the set value of the

"•": means the value of the parameter is the real detection value which can not be modified.

(The inverter has limited the automatic inspection of the modifying character of the parameters to help users avoid mismodifying)

The seventh line "No.": The serial number of function code, at the same time, it also means the register address during communication.

2. "Parameter radix" is decimal (DEC), if the parameter is expressed by hex, then the parameter is separated form each other when editing. The setting range of certain bits are 0~F (hex).

3."The default value" means the function parameter will restore to the default value during default parameters restoring. But the detected parameter or recorded value won't be restored.

4. For a better parameter protection, the inverter provides password protection to the parameters. After setting the password (set F07.00 to any non-zero number), the system will come into the state of password verification firstly after the user press **PRG/ESC** to come into the function code editing state. And then "0.0.0.0.0." will be displayed. Unless the user input right password, they cannot enter into the system. For the factory setting parameter zone, it needs correct factory password (remind that the users

can not modify the factory parameters by themselves, otherwise, if the parameter setting is incorrect, damage to the inverter may occur). If the password protection is unlocked, the user can modify the password freely and the inverter will work as the last setting one. When F7.00 is set to 0, the password can be canceled. If F7.00 is not 0 during powering on, then the parameter is protected by the password. When modify the parameters by serial communication, the function of the password follows the above rules, too.

Function code	Name	Description	Setting range	Factory setting	modify	NO.
F0Group Basic function						
F0.00	Control model	0: V/F control 1: Sensorless vector control 2: Torque control (sensorless vector control)	0~2	0	☉	0.
F0.01	Run command source	0: Keypad (LED extinguished) 1: Terminal (LED flickering) 2: Communication (LED lights on)	0~2	0	☉	1.
F0.02	UP/DOWN	0:Valid, save UP/DOWN	0~3	0	○	2.

Function code	Name	Description	Setting range	Factory setting	modify	NO.
	setting	value when power off 1:Valid, do not save UP/DOWN value when power off 2: Invalid 3: Valid during running, clear when stop.				
F0.03	Maximum frequency	10.00~400.00Hz	10.00~400.00	50.00Hz	☉	3.
F0.04	Upper frequency limit	F0.05~F0.03(the Maximum frequency)	F0.05~F0.03	50.00Hz	○	4.
F0.05	Lower frequency limit	0.00~F0.04(Lower frequency limit)	0.00~F0.04	0.00Hz	○	5.
F0.06	Keypad reference frequency	0.00~F0.03(the Maximum frequency)	0.00~F0.03	50.00Hz	○	6.

Function code	Name	Description	Setting range	Factory setting	modify	NO.
F0.07	Frequency A command source	0: Keypad 1: AI1 2: AI2 3: HDI 4: Simple PLC 5: Multi-stage speed 6: PID 7: Remote communication	0~7	0	<input type="radio"/>	7.
F0.08	Frequency B command source	0: AI1 1: AI2 2: HDI	0~2	0	<input type="radio"/>	8.
F0.09	Scale of frequency B command	0: Maximum frequency 1: Frequency A command	0~1	0	<input type="radio"/>	9.
F0.10	Frequency command selection	0: A 1: B 2: A+B 3: Max (A and B)	0~3	0	<input type="radio"/>	10.

Function code	Name	Description	Setting range	Factory setting	modify	NO.
F0.11	Acceleration time 0	0.1~3600.0s	0.1~3600.0	Depend on model	<input type="radio"/>	11.
F0.12	Deceleration time 0	0.1~3600.0s	0.1~3600.0	Depend on model	<input type="radio"/>	12.
F0.13	Running direction selection	0: Forward 1: Reverse 2: Forbid reverse	0~2	0	<input checked="" type="radio"/>	13.
F0.14	Carrier frequency	1.0~15.0kHz	1.0~15.0	Depend on model	<input type="radio"/>	14.
F0.15	AVR function	0: Invalid 1: Valid all the time 2 : Only valid in deceleration	0~2	1	<input type="radio"/>	15.
F0.16	Motor parameters auto tuning	0: No action 1: Rotation auto tuning 2: Static auto tuning	0~2	0	<input checked="" type="radio"/>	16.

Function code	Name	Description	Setting range	Factory setting	modify	NO.
F0.17	Restore parameters	0: No action 1: Restore factory setting 2: Clear fault records	0~2	0	⊙	17.
F1 Group: Start and Stop Control						
F1.00	Start Mode	0: Start directly 1: DC braking and start 2: Speed tracking and start	0~2	0	⊙	18.
F1.01	Starting frequency	0.00~10.00Hz	0.00~10.00	0.00Hz	⊙	19.
F1.02	Hold time of starting frequency	0.0~50.0s	0.0~50.0	0.0s	⊙	20.
F1.03	DC Braking current before start	0.0~150.0%	0.0~150.0	0.0%	⊙	21.
F1.04	DC Braking time before start	0.0~50.0s	0.0~50.0	0.0s	⊙	22.

Function code	Name	Description	Setting range	Factory setting	modify	NO.
F1.05	Acceleration / Deceleration mode	0: Linear 1: reserved	0~1	0	☉	23.
F1.06	Stop mode	0: Decelerate to stop 1: Coast to stop	0~1	0	○	24.
F1.07	Starting frequency of DC braking	0.00~F0.03	0.00~F0.03	0.00Hz	○	25.
F1.08	Waiting time before DC braking	0.0~50.0s	0.0~50.0	0.0s	○	26.
F1.09	DC braking current	0.0~150.0%	0.0~150.0	0.0%	○	27.
F1.10	DC braking time	0.0~50.0s	0.0~50.0	0.0s	○	28.
F1.11	Dead time of FWD/REV	0.0~3600.0s	0.0~3600.0	0.0s	○	29.

Function code	Name	Description	Setting range	Factory setting	modify	NO.
F1.12	Action when running frequency is less than lower frequency limit (valid when lower frequency limit is above 0)	0: Running at the lower frequency limit 1: Stop 2: Stand-by	0~2	0	<input checked="" type="radio"/>	30.
F1.13	Delay time for restart	0.0~3600.0s (valid when F1.12=2)	0.0~3600.0	0	<input checked="" type="radio"/>	31.
F1.14	Restart after power off	0: Disabled 1: Enabled	0~1	0	<input type="radio"/>	32.
F1.15	Waiting time of restart	0.0~3600.0s (valid when F1.14=1)	0.0~3600.0	0.0s	<input type="radio"/>	33.
F1.16	Terminal detection selection when power on	0: Disabled 1: Enabled	0~1	0	<input type="radio"/>	34.

Function code	Name	Description	Setting range	Factory setting	modify	NO.
F1.17	Reserved	Reserved			⊙	35.
F1.18	Reserved	Reserved			⊙	36.
F1.19	Reserved	Reserved			⊙	37.
F2 Group: Motor Parameters						
F2.00	Inverter model	0: General purpose 1: Pump application	0~1	Depend on model	⊙	38.
F2.01	Motor rated power	0.4~900.0kW	0.4~3000.0	Depend on model	⊙	39.
F2.02	Motor rated frequency	0.01Hz~F0.03	10.00~F0.03	50.00Hz	⊙	40.
F2.03	Motor rated speed	0~36000rpm	0~36000	Depend on model	⊙	41.
F2.04	Motor rated voltage	0~800V	0~800	Depend on model	⊙	42.
F2.05	Motor rated current	0.8~6000.0A	0.8~6000.0	Depend on model	⊙	43.
F2.06	Motor stator resistance	0.001~65.535Ω	0.001~65.535	Depend on model	○	44.

Function code	Name	Description	Setting range	Factory setting	modify	NO.
F2.07	Motor rotor resistance	0.001~65.535Ω	0.001~65.535	Depend on model	<input type="radio"/>	45.
F2.08	Motor leakage inductance	0.1~6553.5mH	0.1~6553.5	Depend on model	<input type="radio"/>	46.
F2.09	Motor mutual inductance;	0.1~6553.5mH	0.1~6553.5	Depend on model	<input type="radio"/>	47.
F2.10	Current without load	0.01~655.35A	0.1~6553.5	Depend on model	<input type="radio"/>	48.
F3 Group: Vector Control						
F3.00	ASR proportional gain K_p1	0~100	0~100	20	<input type="radio"/>	49.
F3.01	ASR integral time K_i1	0.01~10.00s	0.01~10.00s	0.50s	<input type="radio"/>	50.
F3.02	ASR switching point 1	0.00Hz~F3.05	0.00~F3.05	5.00Hz	<input type="radio"/>	51.

Function code	Name	Description	Setting range	Factory setting	modify	NO.
F3.03	ASR proportional gain K_p2	0~100	0~100	25	<input type="radio"/>	52.
F3.04	ASR integral time K_i2	0.01~10.00s	0.01~10.00	1.00s	<input type="radio"/>	53.
F3.05	ASR switching point 2	F3.02~F0.03(the Maximum frequency)	F3.02~F0.03	10.00Hz	<input type="radio"/>	54.
F3.06	Slip compensation rate of VC	50.0%~200.0%	50~200	100%	<input type="radio"/>	55.
F3.07	Torque upper limit	0.0~200.0%(the rated current of the inverter)	0.0~200.0	General purpose : 150.0% Pump application: 120.0%	<input type="radio"/>	56.

Function code	Name	Description	Setting range	Factory setting	modify	NO.
F3.08	Torque setting source	0: Keypad (corresponds to F3.09) 1:A11 2:A12 3:HDI 4:Multi-step speed 5:Remote communication (1~5: 100% corresponds to 2 times of the rated current of the inverter)	0~5	0	<input type="radio"/>	57.
F3.09	Keypad torque setting	-200.0%~200.0%(the rated current of the inverter)	-200.0~200.0	50.0%	<input type="radio"/>	58.
F3.10	Upper frequency setting source	0: Keypad (F0.04) 1: A11 2: A12 3: HDI 4: Multi-step 5:Remote communication (1~4: 100% corresponds to the Max. frequency)	0~5	0	<input type="radio"/>	59.

Function code	Name	Description	Setting range	Factory setting	modify	NO.
F4 Group: V/F Control						
F4.00	V/F curve selection	0:Linear curve 1:Multi dots curve 2: Torque_stepdown curve (1.3 order) 3: Torque_stepdown curve (1.7 order) 4: Torque_stepdown curve (2.0 order)	0~4	0	<input checked="" type="radio"/>	60.
F4.01	Torque boost	0.0%: (auto) 0.1%~10.0%	0.0~10.0	0.0%	<input type="radio"/>	61.
F4.02	Torque boost cut-off	0.0%~50.0% (motor rated frequency)	0.0~50.0	20.0%	<input checked="" type="radio"/>	62.
F4.03	V/F frequency 1	0.00Hz~F4.05	0.00~F4.05	0.00Hz	<input type="radio"/>	63.
F4.04	V/F voltage 1	0.0%~100.0%(the rated voltage of the motor)	0.0~100.0	00.0%	<input type="radio"/>	64.
F4.05	V/F frequency 2	F4.03~F4.07	F4.03~F4.07	00.00Hz	<input type="radio"/>	65.

Function code	Name	Description	Setting range	Factory setting	modify	NO.
F4.06	V/F voltage 2	0.0%~100.0%(the rated voltage of the motor)	0.0~100.0	00.0%	<input type="radio"/>	66.
F4.07	V/F frequency 3	F4.05~ F2.02(the rated frequency of the motor)	F4.05~F2.02	00.00Hz	<input type="radio"/>	67.
F4.08	V/F voltage 3	0.0%~100.0%(the rated voltage of the motor)	0.0~100.0	0.0%	<input type="radio"/>	68.
F4.09	Slip compensation limit	0.00~200.0%	0.0~200.0	0.0%	<input type="radio"/>	69.
F4.10	Auto energy saving selection	0: Disabled 1: Enabled	0~1	0	<input checked="" type="radio"/>	70.
F4.11	Low-frequency threshold of restraining oscillation	0~10	0~10	2	<input type="radio"/>	71.
F4.12	High-frequency threshold of restraining oscillation	0~10	0~10	0	<input type="radio"/>	72.

Function code	Name	Description	Setting range	Factory setting	modify	NO.
F4.13	Boundary of restraining oscillation	0.0~F3.03	0.00~F0.03	30.00 Hz	○	73.
F5 Group: Input Terminals						
F5.00	HDI selection	0: High speed pulse input 1: ON-OFF input	0~1	0	◎	74.
F5.01	S1 Terminal function	0: Invalid 1: Forward 2: Reverse 3: 3-wire control	0~39	1	◎	75.
F5.02	HDI selection	4: Jog forward 5: Jog reverse 6: Coast to stop	0~39	4	◎	76.
F5.03	S1 Terminal function	7: Reset fault 8: Pause running	0~39	7	◎	77.

Function code	Name	Description	Setting range	Factory setting	modify	NO.
F5.04	S2 Terminal function	9: External fault input 10: Up command 11: DOWN command 12: Clear UP/DOWN	0~39	0	☉	78.
F5.05	S3 Terminal function	13: Switch between A and B 14: Switch between A and A+B	0~39	0	☉	79.
F5.06	S4 Terminal function	15: Switch between B and A+B 16: Multi-step speed reference1	0~39	0	☉	80.
F5.07	S5 terminal function	17: Multi-step speed reference 2 18: Multi-step speed reference 3	0~39	0	☉	81.
F5.08	S6 terminal function	19: Multi-step speed reference 4 20: Multi-step speed pause 21: ACC/DEC time selection1n time	0~39	0	☉	82.

Function code	Name	Description	Setting range	Factory setting	modify	NO.
		22: ACC/DEC time selection 2 23: Reset simple PLC when stop 24: Pause simple PLC 25: Pause PID 26: Pause traverse operation 27: Reset traverse operation 28: Reset counter 29: Reset length 30: ACC/DEC ramp hold 31: Counter input 32: UP/DOWN invalid temporarily 33-39: Reserved				
F5.09	ON-OFF filter times	1~10	1~10	5	○	83.
F5.10	FWD/REV control mode	0: 2-wire control mode 1 1: 2-wire control mode 2	0~3	0	◎	84.

Function code	Name	Description	Setting range	Factory setting	modify	NO.
		2: 3-wire control mode 1 3: 3-wire control mode 2				
F5.11	UP/DOWN setting change rate	0.01~50.00Hz/s	0.01~50.00	0.50Hz/s	<input type="radio"/>	85.
F5.12	AI1 lower limit	0.00V~10.00V	-10.00~10.00	0.00V	<input type="radio"/>	86.
F5.13	AI1 lower limit corresponding setting	-100.0%~100.0%	-100.0~100.0	0.0%	<input type="radio"/>	87.
F5.14	AI1 upper limit	0.00V~10.00V	-10.00~10.00	10.00V	<input type="radio"/>	88.
F5.15	AI1 upper limit corresponding setting	-100.0%~100.0%	-100.0~100.0	100.0%	<input type="radio"/>	89.
F5.16	AI1 filter time constant	0.00s~10.00s	0.00~10.00	0.10s	<input type="radio"/>	90.

Function code	Name	Description	Setting range	Factory setting	modify	NO.
F5.17	AI2 lower limit	0.00V~10.00V	0.00~10.00	0.00V	<input type="radio"/>	91.
F5.18	AI2 lower limit corresponding setting	-100.0%~100.0%	-100.0~100.0	0.0%	<input type="radio"/>	92.
F5.19	AI2 upper limit	0.00V~10.00V	0.00~10.00	10.00V	<input type="radio"/>	93.
F5.20	AI2 upper limit corresponding setting	-100.0%~100.0%	-100.0~100.0	100.0%	<input type="radio"/>	94.
F5.21	AI2 filter time constant	0.00s~10.00s	0.00~10.00	0.10s	<input type="radio"/>	95.
F5.22	HDI lower limit	0.0 kHz ~50.0kHz	0.00~50.00	0.00kHz	<input type="radio"/>	96.

Function code	Name	Description	Setting range	Factory setting	modify	NO.
F5.23	HDI lower limit corresponding setting	-100.0%~100.0%	-100.0~100.0	0.0%	<input type="radio"/>	97.
F5.24	HDI upper limit	0.0 KHz~50.0KHz	0.00~50.00	50.00kHz	<input type="radio"/>	98.
F5.25	HDI upper limit corresponding setting	-100.0%~100.0%	-100.0~100.0	100.0%	<input type="radio"/>	99.
F5.26	HDI filter time constant	0.00s~10.00s	0.00~10.00	0.10s	<input type="radio"/>	100.
F6 Group: Output Terminals						
F6.00	HDO selection	0: High-speed pulse output 1: ON-OFF output	0~1	0	<input type="radio"/>	101.
F6.01	HDO ON-OFF output selection	0: No output 1: Running 2: Run forward 3: Run reverse	0~20	1	<input type="radio"/>	102.

Function code	Name	Description	Setting range	Factory setting	modify	NO.
F6.02	Relay 1 output selection	4: Fault output 5: FDT reached 6: Frequency reached	0~20	4	<input type="radio"/>	103.
F6.03	Relay 2 output selection	7: Zero speed running 8: Preset count value reached 9: Specified count value reached 10: Length reached 11: Simple PLC step completed 12: PLC cycle completed 13: Running time reached 14: Upper frequency limit reached 15: Lower frequency limit reached 16: Ready 17: Auxiliary motor 1 started 18: Auxiliary motor 2 started 19-20: Reserved	0~20	0	<input type="radio"/>	104.

Function code	Name	Description	Setting range	Factory setting	modify	NO.
F6.04	AO1 function selection	0: Running frequency 1: Reference frequency 2: Rotation speed	0~10	0	<input type="radio"/>	105.
F6.05	AO2 function selection	3: Output current 4: Output voltage 5: Output power	0~10	0	<input type="radio"/>	106.
F6.06	HDO function selection	6: Output torque 7: AI1 voltage 8: AI2 voltage/current 9: HDI frequency	0~10	0	<input type="radio"/>	107.
F6.07	AO1 lower limit	0.0%~100.0%	0.0~100.0	0.0%	<input type="radio"/>	108.
F6.08	AO1 lower limit corresponding output	0.00V ~10.00V	0.00~10.00	0.00V	<input type="radio"/>	109.
F6.09	AO1 upper limit	0.0%~100.0%	0.0~100.0	100.0%	<input type="radio"/>	110.
F6.10	AO1 upper limit corresponding output	0.00V ~10.00V	0.00~10.00	10.00V	<input type="radio"/>	111.

Function code	Name	Description	Setting range	Factory setting	modify	NO.
F6.11	AO2 lower limit	0.0%~100.0%	0.0~100.0	0.0%	<input type="radio"/>	112.
F6.12	AO2 lower limit corresponding output	0.00V ~10.00V	0.00~10.00	0.00V	<input type="radio"/>	113.
F6.13	AO2 upper limit	0.0%~100.0%	0.0~100.0	100.0%	<input type="radio"/>	114.
F6.14	AO2 upper limit corresponding output	0.00V ~10.00V	0.00~10.00	10.00V	<input type="radio"/>	115.
F6.15	HDO lower limit	0.00%~100.0%	0.00~100.00	0.00%	<input type="radio"/>	116.
F6.16	HDO lower limit corresponding output	0.000~ 50.00kHz	0.000~50.000	0.00kHz	<input type="radio"/>	117.

Function code	Name	Description	Setting range	Factory setting	modify	NO.
F6.17	AO2 lower limit	0.00%~100.0%	0.00~100.00	100.0%	<input type="radio"/>	118.
F6.18	AO2 lower limit corresponding output	0.0 ~ 50.0kHz	0.000~50.000	50.00kHz	<input type="radio"/>	119.
F7 Group: Human and Machine Interface						
F7.00	User password	0~65535	0~65535	0	<input type="radio"/>	120.
F7.01	Reserve	Reserve	Reserve	Reserve	<input type="radio"/>	121.
F7.02	Reserve	Reserve	Reserve	Reserve	<input checked="" type="radio"/>	122.
F7.03	QUICK/JO G function selection	0: Display status switching 1: Jog 2: FWD/REV switching 3: Clear UP/DOWN setting 4.QUICK set mode	0~4	0	<input type="radio"/>	123.
F7.04	STOP/RST function selection	0: Valid when keypad control 1: Valid when keypad or	0~3	0	<input type="radio"/>	124.

Function code	Name	Description	Setting range	Factory setting	modify	NO.
		terminal control 2: Valid when keypad or communication control 3: Always valid				
F7.05	Keypad display selection	0: Preferential to external keypad 1: Both display, only external key valid. 2: Both display, only local key valid. 3: Both display and key valid.	0~3	0	○	125.
F7.06	Running status display selection 1	0~0XFFFF BIT0: running frequency BIT1: Reference frequency BIT2: DC bus voltage BIT3: Output voltage BIT4: Output current BIT5: Rotation speed BIT6: Line speed	0~0XFFFF	0X07FF	○	1.

Function code	Name	Description	Setting range	Factory setting	modify	NO.
		BIT7: Output power BIT8: Output torque BIT9: PID preset BIT10: PID feedback BIT11: Input terminal status BIT12: Output terminal status BIT13: Torque setting value BIT14: Count value BIT15: Step No. of PLC or multi-step				
F7.07	Running status display selection 2	0~0XFFFF BIT0: AI1 BIT1: AI2 BIT2: HDI frequency BIT3: Load percentage of motor BIT4: Load percentage of inverter BIT5~15: Reserved	0~0XFFFF	0	○	126.

Function code	Name	Description	Setting range	Factory setting	modify	NO.
F7.08	Stop status display selection	0~0XFFFF BIT0: Reference frequency BIT1: DC bus voltage BIT2: Input terminal status BIT3: Output terminal status BIT4: PID preset BIT5: PID feedback BIT6: AI1 BIT7: AI2 BIT8: HDI frequency BIT9: Step No. of PLC or multi-step BIT10: Torque setting value BIT11~ BIT15: Reserved	0~0XFFFF	0x00FF	<input type="radio"/>	127.
F7.09	Coefficient of rotation speed	0.1~999.9% Actual mechanical speed = 120 * output frequency *F7.09 / Number of poles of motor	0.1~999.9	100.0%	<input type="radio"/>	128.

Function code	Name	Description	Setting range	Factory setting	modify	NO.
F7.10	Coefficient of line speed	0.1~999.9% Line speed = actual mechanical speed * F7.10	0.1~999.9	1.0%	<input type="radio"/>	129.
F7.11	Rectify module temperature	0~100.0°C			<input checked="" type="radio"/>	130.
F7.12	IGBT module temperature	0~100.0°C			<input checked="" type="radio"/>	131.
F7.13	Software version				<input checked="" type="radio"/>	132.
F7.14	Inverter rated power	0.4~3000.0kW	0.4~3000.0	机型确定	<input checked="" type="radio"/>	133.
F7.15	Inverter rated current	0.0~6000.0A	0.0~6000.0	机型确定	<input checked="" type="radio"/>	134.
F7.16	Accumulated running time	0~65535h			<input checked="" type="radio"/>	135.

Function code	Name	Description	Setting range	Factory setting	modify	NO.
F7.17	Third latest fault type	0: Not fault 1: IGBT Ph-U fault(SC) 2: IGBT Ph-V fault(SC1)			●	136.
F7.18	Second latest fault type	3: IGBT Ph-W fault(SC2) 4: Over-current when acceleration(OC1)			●	137.
F7.19	Latest fault type	5: Over-current when deceleration(OC2) 6: Over-current when constant speed running (OC3) 7: Over-voltage when acceleration(OV1) 8: Over-voltage when deceleration(OV2) 9: Over-voltage when constant speed running(OV3)			●	138.

Function code	Name	Description	Setting range	Factory setting	modify	NO.
		10: DC bus Under-voltage(UV)				
		11: Motor overload (OL1)				
		12: Inverter overload (OL2)				
		13: Input phase failure (SPI)				
		14: Output phase failure (SPO)				
		15: Rectify overheat (OH1)				
		16: IGBT overheat (OH2)				
		17: External fault (EF)				
		18: Communication fault (CE)				
		19: Current detection fault (ITE)				
		20: auto tuning fault (TE)				
		21: EEPROM fault (EEP)				
		22: PID feedback fault (PIDE)				

Function code	Name	Description	Setting range	Factory setting	modify	NO.
		23: Braking unit fault (BCE) 24: Running time arrival (END) 25: over torque fault (OL3)				
F7.20	Output frequency at current fault				●	139.
F7.21	Output current at current fault				●	140.
F7.22	DC bus voltage at current fault				●	141.
F7.23	Input terminal status at current fault				●	142.

Function code	Name	Description	Setting range	Factory setting	modify	NO.
F7.24	Output terminal status at current fault				●	143.
F8 Group: Enhanced Function						
F8.00	Acceleration time 1	0.1~3600.0s	0.1~3600.0	Depend on model	○	144.
F8.01	Deceleration time 1	0.1~3600.0s	0.1~3600.0	Depend on model	○	145.
F8.02	Acceleration time 2	0.1~3600.0s	0.1~3600.0	Depend on model	○	146.
F8.03	Deceleration time 2	0.1~3600.0s	0.1~3600.0	Depend on model	○	147.
F8.04	Acceleration time 3	0.1~3600.0s	0.1~3600.0	Depend on model	○	148.

Function code	Name	Description	Setting range	Factory setting	modify	NO.
F8.05	Deceleration time 3	0.1~3600.0s	0.1~3600.0	Depend on model	<input type="radio"/>	149.
F8.06	Jog reference	0.00~F0.03 (MAX)	0.00~F0.03	5.00Hz	<input type="radio"/>	150.
F8.07	Jog accelerating time	0.1~3600.0s	0.1~3600.0	Depend on model	<input type="radio"/>	151.
F8.08	Jog deceleration time	0.1~3600.0s	0.1~3600.0	Depend on model	<input type="radio"/>	152.
F8.09	Skip Frequency 1	0.00~F0.03 (MAX)	0.00~F0.03	0.00Hz	<input type="radio"/>	153.
F8.10	Skip Frequency 2	0.00~F0.03 (MAX)	0.00~F0.03	0.00Hz	<input type="radio"/>	154.
F8.11	Skip frequency bandwidth	0.00~F0.03 (MAX)	0.00~F0.03	0.00Hz	<input type="radio"/>	155.

Function code	Name	Description	Setting range	Factory setting	modify	NO.
F8.12	Traverse amplitude	0.0~100.0%Relative frequency set)	0.0~100.0	0.0%	<input type="radio"/>	156.
F8.13	Jumper frequency	0.0~50.0% (Relative put frequency range)	0.0~50.0	0.0%	<input type="radio"/>	157.
F8.14	Rise time of traverse	0.1~3600.0s	0.1~3600.0	5.0s	<input type="radio"/>	158.
F8.15	Fall time of traverse	0.1~3600.0s	0.1~3600.0	5.0s	<input type="radio"/>	159.
F8.16	Auto reset times	0~3	0~3	0	<input type="radio"/>	160.
F8.17	Reset interval	0.1~100.0s	0.1~100.0	1.0s	<input type="radio"/>	161.
F8.18	Preset count value	F8.19~65535	F8.19~65535	0	<input type="radio"/>	162.
F8.19	Specified count value	0~F8.18	0~F8.18	0	<input type="radio"/>	163.
F8.20	Preset running time	0~65535h	0~65535	65535h	<input type="radio"/>	164.

Function code	Name	Description	Setting range	Factory setting	modify	NO.
F8.21	FDT level	0.00~ F0.03 (MAX)	0.00~ F0.03	50.00Hz	<input type="radio"/>	165.
F8.22	FDT lag	0.0~100.0% (FDT LEVEL)	0.0~100.0	5.0%	<input type="radio"/>	166.
F8.23	Frequency arrive detecting range	0.0~100.0% (MAX)	0.0~100.0	0.0%	<input type="radio"/>	167.
F8.24	Droop control	0.00~10.00Hz	0.00~10.00	0.00Hz	<input type="radio"/>	168.
F8.25	Brake	115.0~140.0% (Standard DC BUS voltage) (380V)	115.0~140.0	130.0%	<input type="radio"/>	169.
		115.0~140.0% (Standard DC BUS voltage) (220V)	115.0~140.0	120.0%		
F8.26	threshold voltage Cooling fan control	0: Auto stop mode 1: Always working	0~1	0	<input type="radio"/>	170.

Function code	Name	Description	Setting range	Factory setting	modify	NO.
F8.27	Restrain oscillation	0: Enabled 1: Disabled	0~1	0	<input type="radio"/>	171.
F8.28	PWM mode	0: PWM mode 1 1: PWM mode 2 2: PWM mode 3	0~2	0	<input checked="" type="radio"/>	172.
F9 Group: PID Control						
F9.00	PID preset source selection	0: Keypad(F9.01) 1: AI1 2: AI2 3: HDI 4: Multi-step 5: Remote communication	0~5	0	<input type="radio"/>	173.
F9.01	Keypad PID preset	0.0%~100.0%	0.0~100.0	0.0%	<input type="radio"/>	174.
F9.02	PID feedback source selection	0: AI1 1: AI2 2: AI1+AI2 3: HDI 4: Communication	0~3	0	<input type="radio"/>	175.

Function code	Name	Description	Setting range	Factory setting	modify	NO.
F9.03	PID output characteristic	0: Positive 1: Negative	0~1	0	<input type="radio"/>	176.
F9.04	Proportional gain (Kp)	0.00~100.00	0.00~100.00	0.10s	<input type="radio"/>	177.
F9.05	Integral time (Ti)	0.01~10.00s	0.01~10.00	0.10s	<input type="radio"/>	178.
F9.06	Differential time (Td)	0.00~10.00s	0.00~10.00	0.00s	<input type="radio"/>	179.
F9.07	Sampling cycle (T)	0.00~100.00s	0.00~100.00	0.10s	<input type="radio"/>	180.
F9.08	Bias limit	0.0~100.0%	0.0~100.0	0.0%	<input type="radio"/>	181.
F9.09	Feedback lost detecting value	0.0~100.0%	0.0~100.0%	0.0%	<input type="radio"/>	182.
F9.10	Feedback lost detecting time	0.0~3600.0s	0.0~3600.0	1.0s	<input type="radio"/>	183.

Function code	Name	Description	Setting range	Factory setting	modify	NO.
FA Group: Simple PLC and Multi-step Speed Control						
FA.00	Simple PLC mode	0: Stop after one cycle 1: Hold last frequency after one cycle 2: Circular run	0~2	0	<input type="radio"/>	184.
FA.01	Simple PLC status saving after power off	0: Disabled 1: Enabled	0~1	0	<input type="radio"/>	185.
FA.02	Multi-step speed 0	-100.0~100.0%	-100.0~100.0	0.0%	<input type="radio"/>	186.
FA.03	0 th Step running time	0.0~6553.5s (m)	0.0~6553.5	0.0s	<input type="radio"/>	187.
FA.04	Multi-step speed 1	-100.0~100.0%	-100.0~100.0	0.0%	<input type="radio"/>	188.
FA.05	1 st Step running time	0.0~6553.5s (m)	0.0~6553.5	0.0s	<input type="radio"/>	189.

Function code	Name	Description	Setting range	Factory setting	modify	NO.
FA.06	Multi-step speed 2	-100.0~100.0%	-100.0~100.0	0.0%	<input type="radio"/>	190.
FA.07	2 nd Step running time	0.0~6553.5s (m)	0.0~6553.5	0.0s	<input type="radio"/>	191.
FA.08	Multi-step speed 3	-100.0~100.0%	-100.0~100.0	0.0%	<input type="radio"/>	192.
FA.09	3 rd Step running time	0.0~6553.5s (m)	0.0~6553.5	0.0s	<input type="radio"/>	193.
FA.10	Multi-step speed 4	-100.0~100.0%	-100.0~100.0	0.0%	<input type="radio"/>	194.
FA.11	4 th Step running time	0.0~6553.5s (m)	0.0~6553.5	0.0s	<input type="radio"/>	195.
FA.12	Multi-step speed 5	-100.0~100.0%	-100.0~100.0	0.0%	<input type="radio"/>	196.
FA.13	5 th Step running time	0.0~6553.5s (m)	0.0~6553.5	0.0s	<input type="radio"/>	197.

Function code	Name	Description	Setting range	Factory setting	modify	NO.
FA.14	Multi-step speed 6	-100.0~100.0%	-100.0~100.0	0.0%	<input type="radio"/>	198.
FA.15	6 th Step running time	0.0~6553.5s (m)	0.0~6553.5	0.0s	<input type="radio"/>	199.
FA.16	Multi-step speed 7	-100.0~100.0%	-100.0~100.0	0.0%	<input type="radio"/>	200.
FA.17	7 th Step running time	0.0~6553.5s (m)	0.0~6553.5	0.0s	<input type="radio"/>	201.
FA.18	Multi-step speed 8	-100.0~100.0%	-100.0~100.0	0.0%	<input type="radio"/>	202.
FA.19	8 th Step running time	0.0~6553.5s (m)	0.0~6553.5	0.0s	<input type="radio"/>	203.
FA.20	Multi-step speed 9	-100.0~100.0%	-100.0~100.0	0.0%	<input type="radio"/>	204.
FA.21	9 th Step running time	0.0~6553.5s (m)	0.0~6553.5	0.0s	<input type="radio"/>	205.

Function code	Name	Description	Setting range	Factory setting	modify	NO.
FA.22	Multi-step speed 10	-100.0~100.0%	-100.0~100.0	0.0%	<input type="radio"/>	206.
FA.23	10 th Step running time	0.0~6553.5s (m)	0.0~6553.5	0.0s	<input type="radio"/>	207.
FA.24	Multi-step speed 11	-100.0~100.0%	-100.0~100.0	0.0%	<input type="radio"/>	208.
FA.25	11 th Step running time	0.0~6553.5s (m)	0.0~6553.5	0.0s	<input type="radio"/>	209.
FA.26	Multi-step speed 12	-100.0~100.0%	-100.0~100.0	0.0%	<input type="radio"/>	210.
FA.27	12 th Step running time	0.0~6553.5s (m)	0.0~6553.5	0.0s	<input type="radio"/>	211.
FA.28	Multi-step speed 13	-100.0~100.0%	-100.0~100.0	0.0%	<input type="radio"/>	212.
FA.29	13 th Step running time	0.0~6553.5s (m)	0.0~6553.5	0.0s	<input type="radio"/>	213.

Function code	Name	Description	Setting range	Factory setting	modify	NO.
FA.30	Multi-step speed 14	-100.0~100.0%	-100.0~100.0	0.0%	<input type="radio"/>	214.
FA.31	14 th Step running time	0.0~6553.5s (m)	0.0~6553.5	0.0s	<input type="radio"/>	215.
FA.32	Multi-step speed 15	-100.0~100.0%	-100.0~100.0	0.0%	<input type="radio"/>	216.
FA.33	15 th Step running time	0.0~6553.5s (m)	0.0~6553.5	0.0s	<input type="radio"/>	217.
FA.34	ACC/DEC time selection for step 0~7	0~0XFFFF	0~0XFFFF	0	<input type="radio"/>	218.
FA.35	ACC/DEC time selection for step 8~15	0~0XFFFF	0~0XFFFF	0	<input type="radio"/>	219.
FA.36	Simple PLC restart selection	0: Restart from step 0 1: Continue from paused step	0~1	0	<input checked="" type="radio"/>	220.

Function code	Name	Description	Setting range	Factory setting	modify	NO.
FA.37	Time unit	0: Second 1: Minute	0~1	0	☉	221.
Fb Group: Protection Function						
Fb.00	Input phase-failure protection	0: Disable 1: Enable	0~1	1	○	222.
Fb.01	Output phase-failure protection	0: Disabled 1: Enabled	0~1	1	○	223.
Fb.02	Motor overload protection	0: Disabled 1: Normal motor(with low speed compensation) 2: Variable frequency motor(without low speed compensation)	0~2	2	☉	224.
Fb.03	Motor overload	20.0% ~ 120.0% (rated current of the motor)	20.0~120.0	100.0%	○	225.

Function code	Name	Description	Setting range	Factory setting	modify	NO.
	protection current					
Fb.04	Threshold of trip-free	70.0.0~110.0% (standard bus voltage)	70.0~110.0	80.0%	<input type="radio"/>	226.
Fb.05	Decrease rate of trip-free	0.00~F0.03 (the Max. frequency)	0.00~F0.03	0.00Hz/s	<input type="radio"/>	227.
Fb.06	Over-voltage stall protection	0: Disabled 1: Enabled	0~1	1	<input type="radio"/>	228.
Fb.07	Over-voltage stall protection point	110~150%	110~150	120%	<input type="radio"/>	229.
Fb.08	Auto current limiting threshold	50~200%	50~200	General purpose : 160% Pump applicati	<input type="radio"/>	230.

Function code	Name	Description	Setting range	Factory setting	modify	NO.
				on: 120%		
Fb.09	Frequency decrease rate when current limiting	0.00~100.00Hz/s	0.00~100.00	10.00Hz/s	<input type="radio"/>	231.
Fb.10	Auto current limiting selection	0: Enabled 1: Disabled when constant speed	0~1	0	<input type="radio"/>	232.
Fb.11	Selection of over torque (OL3)	0: No detection 1: Valid detection of over torque during running, then continue running 2: Valid detection of over torque during running, then warning and stop 3: Valid detection of over	0~4	1	<input type="radio"/>	233.

Function code	Name	Description	Setting range	Factory setting	modify	NO.
		torque during constant speed running, then continue running 4: Valid detection of over torque during constant speed running, then warning and stop.				
Fb.12	Detection level of over torque	10.0%~200.0%(relative to the rated current of the motor)	1.0~200.0	General purpose : 150.0% Pump application: 120.0%	<input type="radio"/>	234.
Fb.13	Detection time of over torque	0.1~60.0s	0.0~60.0	0.1s	<input type="radio"/>	235.
Fb.14	Reserved				<input checked="" type="radio"/>	236.

Function code	Name	Description	Setting range	Factory setting	modify	NO.
Fb.15	Reserved				●	237.
FC Group: Serial Communication						
FC.00	Local address	0~247, 0 stands for the broadcast address	0~247	1	○	238.
FC.01	Baud rate selection	0: 1200BPS 1: 2400BPS 2: 4800BPS 3: 9600BPS 4: 19200BPS 5: 38400BPS	0~5	4	○	239.
FC.02	Data format	0: RTU, 1 start bit, 8 data bits, no parity check, 1 stop bit. 1: RTU, 1 start bit, 8 data bits, even parity check, 1 stop bit. 2: RTU, 1 start bit, 8 data bits, odd parity check, 1 stop bit.	0~5	1	○	240.

Function code	Name	Description	Setting range	Factory setting	modify	NO.
		3: RTU, 1 start bit, 8 data bits, no parity check, 2 stop bits. 4: RTU, 1 start bit, 8 data bits, even parity check, 2 stop bits. 5: RTU, 1 start bit, 8 data bits, odd parity check, 2 stop bits.				
FC.03	Communication delay time	0~200ms	0~200	5ms	<input type="radio"/>	241.
FC.04	Communication timeout delay	0.0: Disabled 0.1~100.0s	0.0~100.0	0.0s	<input type="radio"/>	242.
FC.05	Communication error action	0: Alarm and coast to stop 1: No alarm and continue to run 2: No alarm but stop	0~3	1	<input type="radio"/>	243.

Function code	Name	Description	Setting range	Factory setting	modify	NO.
		according to F1.06 (if F0.03=2) 3: No alarm but stop according to F1.06				
FC.06	Response action	Unit's place of LED 0: Response to writing 1: No response to writing Ten's place of LED 0: Reference not saved when power off 1: Reference saved when power off	00~11	00	○	244.
FD Group: Supplementary Function						
FE Group: Factory Setting						



Advanced Control[®], Advanced Systems Baltic OÜ
Punane 73, 13619 Tallinn, Estonia
Phone: +372 622 82 20, Fax: +372 622 82 21
Web: www.advcontrol.eu, e-mail: info@advcontrol.eu

Subject to change without prior notice